

Snap-on[®]

DTT DIGITAL TORQUE TESTER

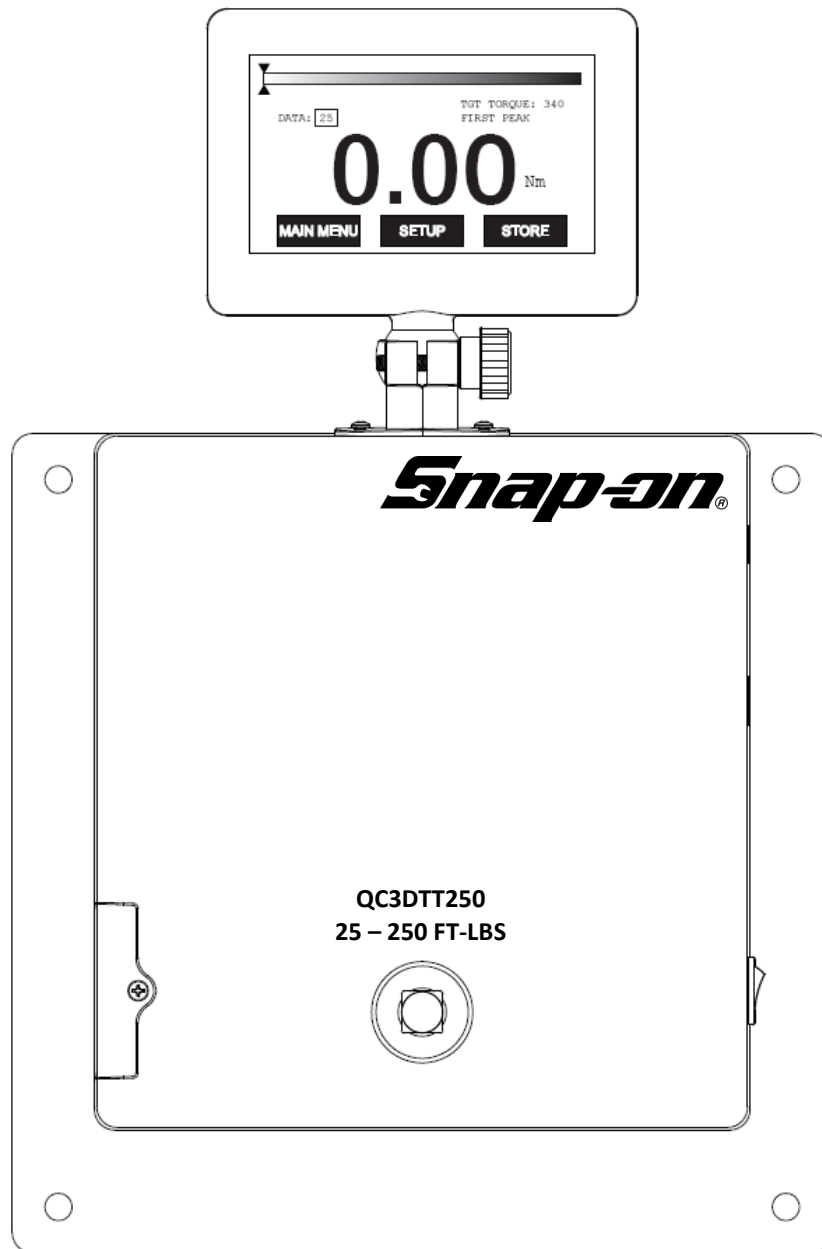

Table of Contents

Important Safety Instructions.....	1
General Safety.....	2
AC Adapter Safety.....	3
DTT System Componentes.....	4
Introduction.....	5
Functional Description.....	6
Specifications.....	7
Torque Range and Display Units.....	8
Setup.....	9
DTT Tester Setup.....	10
Set Date & Time.....	11
Touchscreen Calibration.....	12
➤ Set Brightness	
➤ Sensor calibration	
Tests.....	13
Quick Check.....	14
Audit CW & CCW.....	15
➤ Audit CW & CCW (Cont.).....	16
Audit CW.....	17
➤ Audit CW (Cont.).....	18
Audit CCW.....	19
➤ Audit CCW (Cont.).....	20
Data Offload Win 10 and Earlier.....	21
Data Offload Single Stream.....	22
Win 11 Data Offload.....	23
DTT “OVERTORQUE” Message 110% - 124% of Scale.....	24
DTT “OVERTORQUE” Message 125% of Scale.....	24

IMPORTANT SAFETY INSTRUCTIONS

This manual contains important safety and operating instructions for the Digital Torque Tester (DTT).

Read All Instructions

Read, understand and follow all safety messages and instructions in this manual and on the test equipment. Safety messages in this section of the manual contain a signal word, a three-part message, and, in some instances, an icon. An icon, when present, gives a graphical description of the potential hazard

General Cautions

Snap-on cannot anticipate or provide safety warnings and cautions to cover every situation that may be encountered when operating, servicing or repairing this tester. It is the responsibility of operators and servicing technicians to be knowledgeable about the procedures, tools and materials used, and to satisfy themselves that the procedures, tools and materials will not compromise their safety.

Do not attempt to operate this Digital Torque Tester until you have thoroughly read and completely understand all instructions and safety information in this manual. Failure to comply can result in accidents involving fire, electric shock or serious personal injury. Save this manual and review it frequently for continued safe operation, and use it to instruct others who may use this tester.

Snap-on is not responsible for customer modification of test equipment for applications on which Snap-on was not consulted.

General Safety

WARNING



Improper use can cause breakage.

- **Read instructions before operating.**
- **Follow manufacturer's instructions, safety precautions, and specifications when operating tools.**

Broken equipment can cause injury.



Flying particles can be discharged when applying torque.

Users and bystanders must wear safety goggles.

Flying particles can cause injury.



Risk of entanglement.

- **Keep body parts away from rotating parts.**
- **Wear a protective hair covering to contain long hair and prevent contact with moving parts.**
- **Do not overreach. Keep proper footing and balance at all times.**

Entanglement can cause injury.

Torque Tester Safety

WARNING

- **Be sure ratings for all components, including, adaptors, extensions, drivers and sockets, match or exceed the torque being applied.**
- **Do not use this instrument with power switch OFF. Always turn power switch ON so torque values are displayed.**
- **Do not turn the power switch ON with a torque instrument engaged to tester transducer.**
- **Be sure the capacity of the DTT matches or exceeds each application before performing a procedure.**
- **Pull on a wrench handle—do not push—when tester is mounted horizontally. Adjust stance to prevent a possible fall.**
- **Do not use extensions, such as a pipe, on a wrench handle.**
- **Fully engage the direction lever in the correct position when using ratchets.**

- Never attempt to test an impact tool or pulse type tool on this instrument.
- Mount the DTT securely to a heavy bench, wall or other support structure before applying torque.
- Do not use the DTT if it makes unusual noises, has loose parts, or shows any other sign of damage. Have repairs performed at an Authorized Service Center before use.
- Do not use chipped, cracked, or damaged sockets and accessories.
- Do not remove any labels. Replace any damaged label.

AC Adapter Safety

 **WARNING**



Risk of electric shock and fire.

- Do not allow conductive objects to come in contact with terminals. 120 or 220 volts present at adapter terminals.
- For indoor use only. Do not expose adapter to rain or snow. Do not use in damp locations.
- Replace defective cord immediately. Return to qualified service center for replacement.
- Do not use any other type of adapter. Using an adapter not specifically designed for this unit may damage tester.
- Do not use an extension cord with adapter.
- Do not use a damaged adapter.
- Do not disassemble adapter.
- Do not attempt to connect two adapters together.
- Do not operate adapter with damaged cord or plug. Replace immediately.
- Do not operate adapter after it is dropped, receives a sharp blow or damaged. Take the adapter to an Authorized Service Center.
- Unplug adapter from outlet before maintenance or cleaning. Turning off tester is not adequate to avoid hazard.
- Read all instructions and safety messages on battery and adapter before use.

Electric shock or fire can cause injury.

SAVE THESE INSTRUCTIONS

DTT System Components

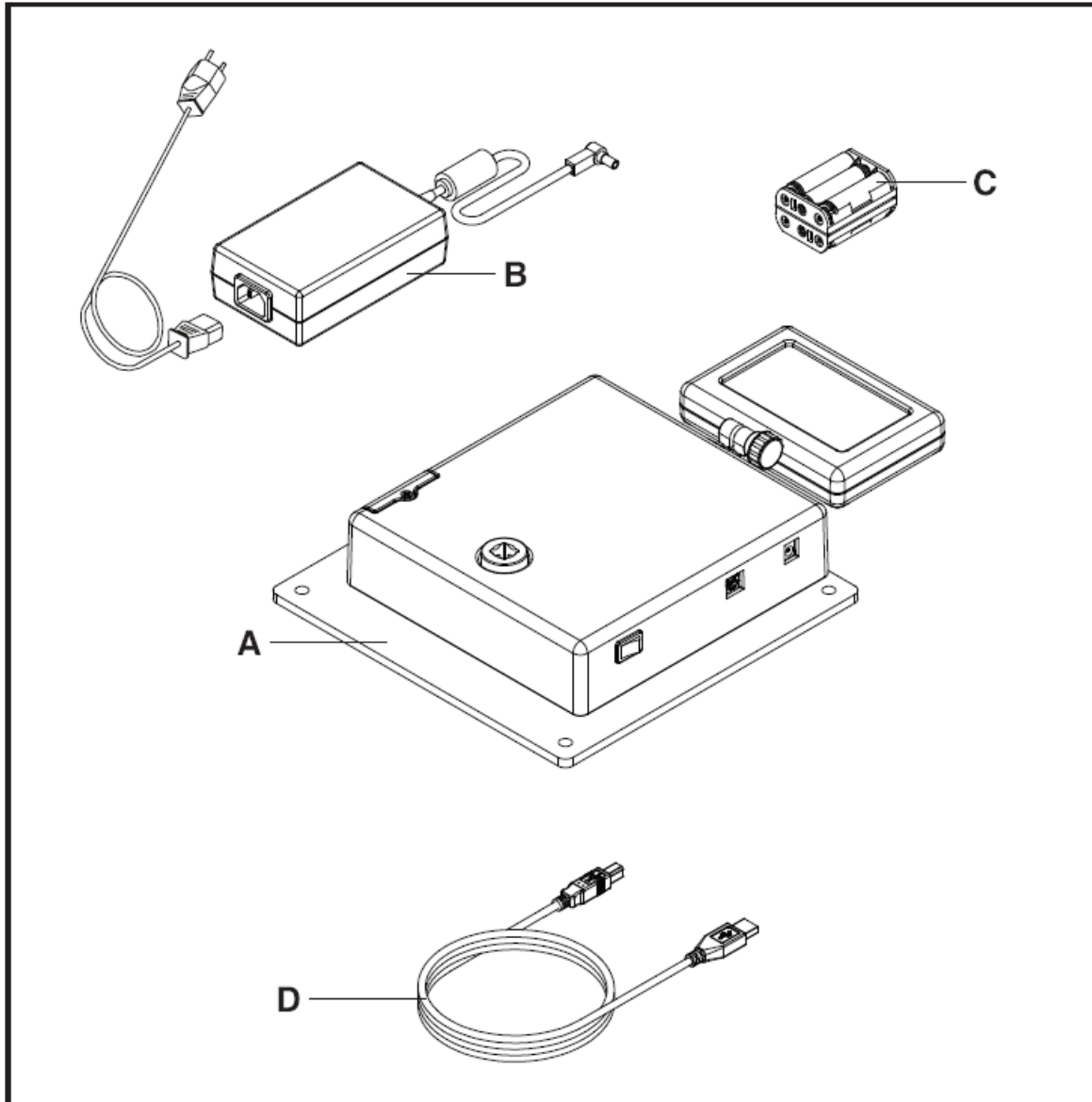

Figure 1: Digital Torque Tester System Components

A – DTT

B – AC Adapter

AC/DC transformer, Voltage Output: 9VDC, Current 1.66A

C – Battery Pack

Battery holder with 6 AA Batteries

D – USB Cable

!IMPORTANT!

Confirm that the “Battery Pack” (C) is always connected to the “Battery Pack” Cable Connector, when installing fresh batteries

DTT Digital Torque Tester

Introduction

Use the portable DTT to test “click” type torque wrenches (adjustable and preset), torque screwdrivers, dial indicating and electronic wrenches.

The tester features a swivel-neck LCD display with selectable Metric or English units of measure.

The DTT displays torque values using a built-in strain-gaged transducer with an accuracy of $\pm 0.5\%$ of indicated test value from 10% to 100% of rated capacity, in clockwise (CW) and counterclockwise (CCW) directions

Torque Values

Capture and display torque values in one of three Selectable modes:

- **CLICK ADJUST (First Peak)**
 - Responds to the drop-off in torque caused by the “click” of an adjustable torque wrench. FIRST PEAK Torque is measured, captured and displayed (CW or CCW) just prior to the drop-off, even if click torque is subsequently exceeded.
- **TRACK**
 - Continuous readout of torque applied at any moment
- **DIAL / ELEC (Peak Hold)**
 - Captures and displays the highest torque applied (CW or CCW) until reset. Use this mode to check dial indicating and electronic torque wrenches.
- **SCREWDRIVER (Peak Hold)**
 - Captures and displays the highest torque applied (CW or CCW) until reset. Use this mode to check torque limiting screwdrivers.

Power Source

The power source for the DTT is the supplied AC Adapter. The tester can also be operated with the use of 6 AA battery pack that accompanies the tester.

This manual contains general information. Operating features and specifications may change without notice. Snap-on makes no claims regarding the suitability of the information in this manual for diverse user applications.

Functional Description

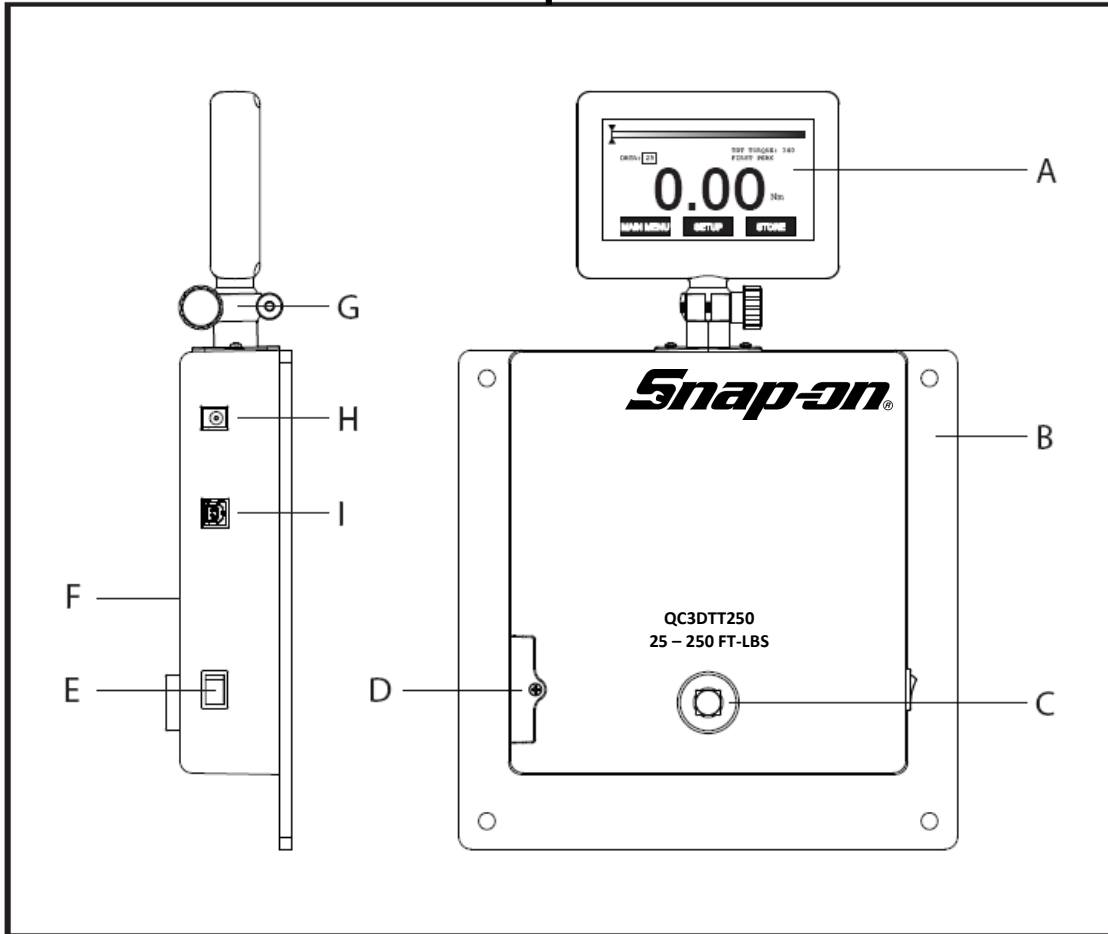

Figure 2: Digital Torque Tester System Components

A – Display

Four-digit TFT display for torque readings.

B – Mounting Plate

Plate for securing tester to mounting surface. Use four M6 diameter bolts.

C – Transducer

Female square drive

D – Battery Access

Battery pack housing panel. Remove Phillips screw to access battery pack

E – Power Switch

Rocker switch powers tester ON and OFF.

F – Audible Alert

Signals sounds momentarily when:

- Power to tester is initiated
- Anytime a button is pressed
- Target Torque is reached

G – Swivel

Holds the display view from any angle

H – AC Adapter Jack

Receptacle (9VDC @ 1.66A max) for continuous AC operation.

I – USB Jack

Receptacle for uploading torque data to external computer

DTT Digital Torque Tester

Specifications

Display

LCD on swivel neck

Display Specifications

Size: 4.7 inches (11.9 cm)

Accuracy

±0.5% of indicated test value CW & CCW directions from 10% to 100% of rated capacity on all DTT applications.

Units of Measurement

FT-LBS, IN-LBS, IN-OZ, NM, CNM, DNM, KG-CM and KGM.

*Some unit selections are limited to torque range of DTT Tester.

Operating Temperature

32 to 122 F° (0 to 50°C)

Storage Temperature

-4 to 158 F° (-20 to 70°C)

Dimensions

Width – 9.60 inches (24.4 cm)

Height – 15.20 inches (38.6 cm)

Depth – 2.50 inches (6.3 cm)

Weight

11 lbs (5 kg)

Battery

Six 1.5V (AA), replaceable

AC Adapter

Input - 100 ~ 240VAC (50-60 Hz)

Output - 9VDC, 1.66A

Integral Transducer

Full bridge strain gage.

350 ohms, 1500 µE, 3mV/V F.S., 3.3V excitation

Transducer Range and Display Resolutions

DTT built-in transducers provide industry standard female square drives, and a full bridge strain gage sensing element.

Contact your Snap-on representative for service and/or calibration.

IMPORTANT

Apply torque loads only. Never side-load a wrench while installed on the tester transducer.

IMPORTANT

Transducers can withstand a torque of 125% of rated capacity.

Do not use the tester if the transducer:

- Does not zero
- Does not calibrate
- Has been over-torqued.

DTT Digital Torque Tester

Setup

Mounting

Mount the DTT to a sturdy support before use. Torque testing procedures may involve 16 lbs of load. Be sure to consider counterweight of the mount to accommodate torque testing operations and testing fixtures. Allow enough room around and below the mount for the wrenches or testing fixtures being used.

Vertical mounting on a wall or heavy pillar is preferred for most wrench and tool testing as shown in the illustration below. Use four M6 diameter bolts (torqued to 10 ft-lbs) to insure a secure mount. The DTT can also be mounted vertically to a horizontal surface using a right angle bracket.

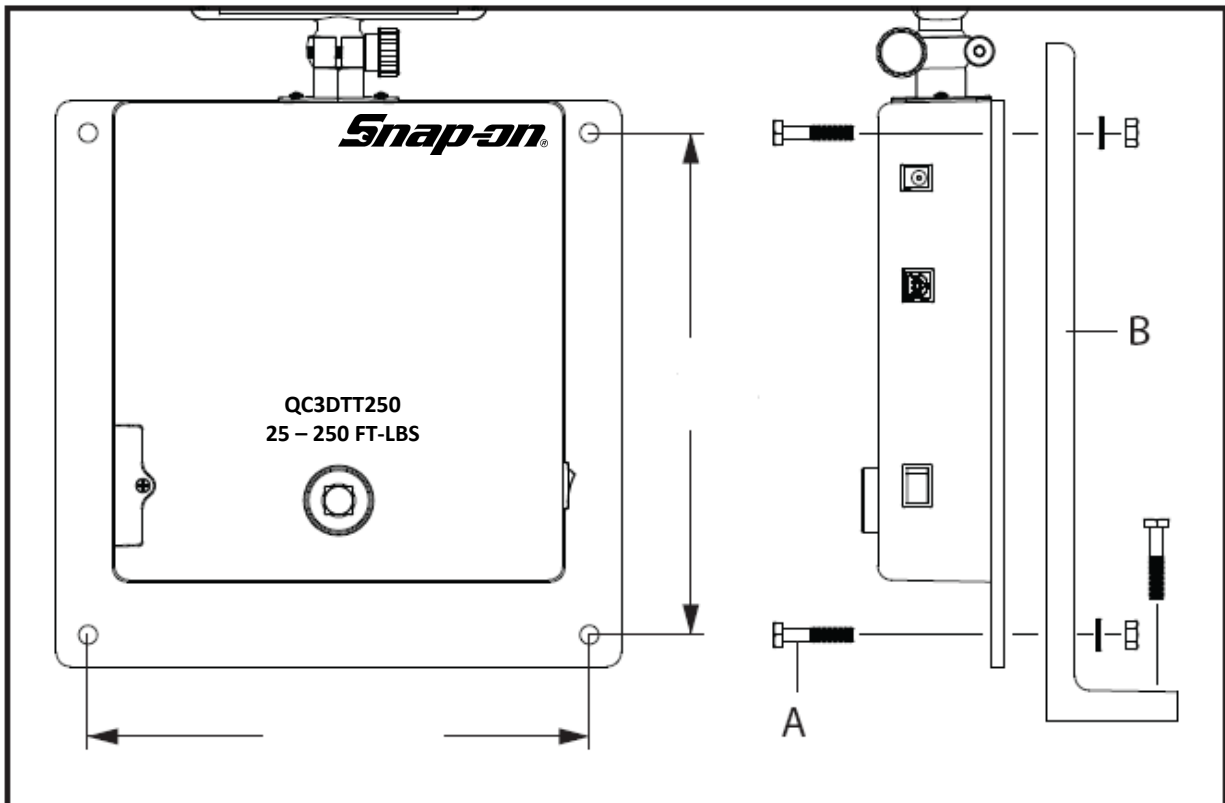

Figure 3: Digital Torque Tester System Components

A – Mounting Screws (4)

B – Right Angle Bracket

P/N: 2344-0050-03 sold separately

DTT Digital Torque Tester

DTT Tester Setup

DTT Main Screen Buttonology (Power ON DTT Tester)

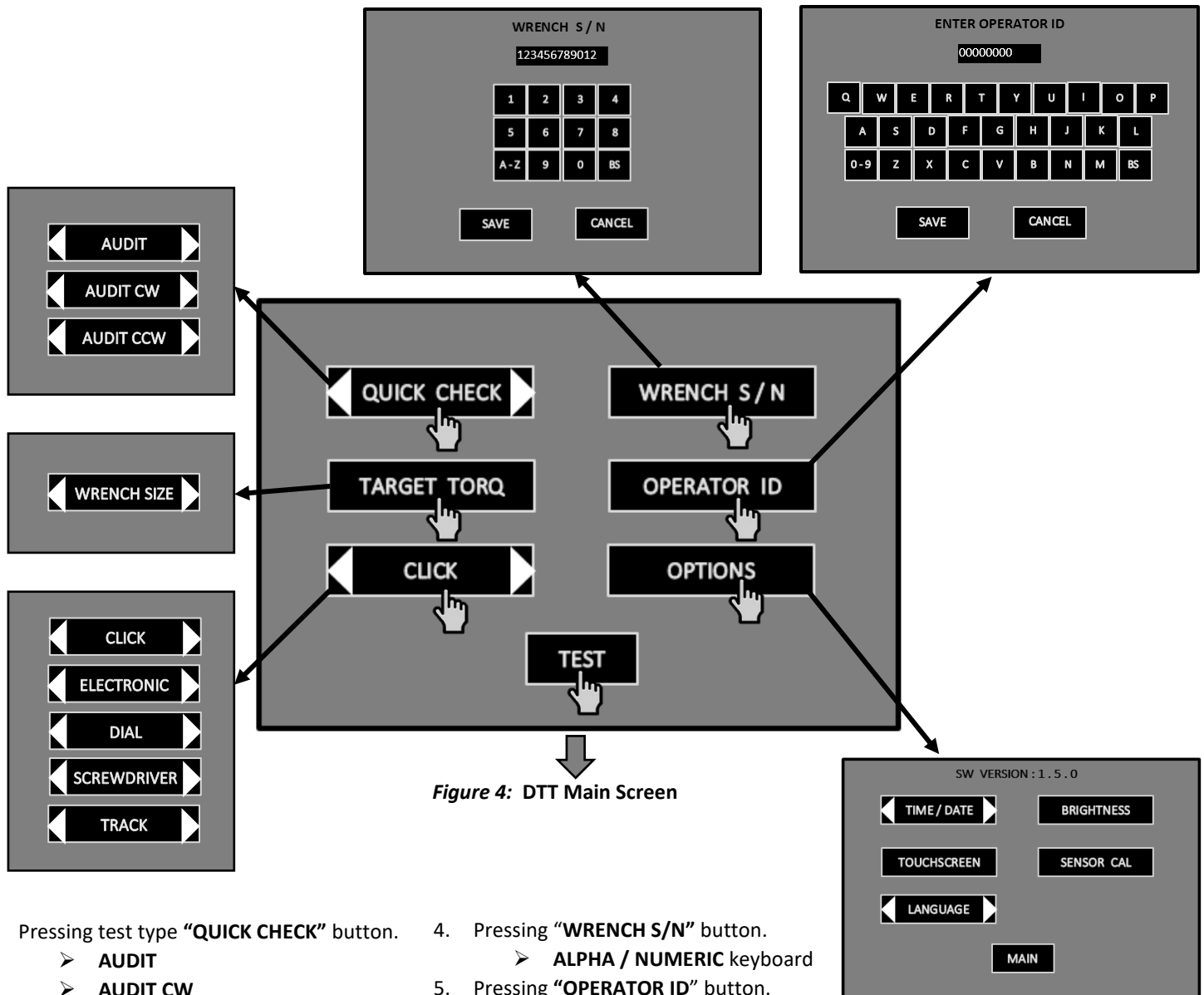

Figure 4: DTT Main Screen

- Pressing test type "QUICK CHECK" button.
 - **AUDIT**
 - **AUDIT CW**
 - **AUDIT CCW**
- Pressing "TARGET TORQ" button.
 - **WRENCH SIZE** appears when test type **AUDIT**, **AUDIT CW** and **AUDIT CCW** is selected.
- Pressing wrench type "CLICK" button.
 - **CLICK** (First Peak)
 - **ELECTRONIC** (Peak)
 - **DIAL** (Peak)
 - **SCREWDRIVER** (Peak)
 - **TRACK**
- Pressing "WRENCH S/N" button.
 - **ALPHA / NUMERIC** keyboard
- Pressing "OPERATOR ID" button.
 - **ALPHA / NUMERIC** keyboard
- Pressing "OPTION" button.
 - **TIME / DATE** (Enter time / date)
 - **TOUCHSCREEN** (Calibration)
 - **LANGUAGE** (English / French)
 - **DECIMAL / COMMA** (Number Separator)
 - **BRIGHTNESS** (LCD screen adjustment)
 - **SENSOR CAL** (Calibrate Sensor)
 - **MAIN** (Back to Main Screen)

Set Date and Time

Figure 5: DTT Main Screen

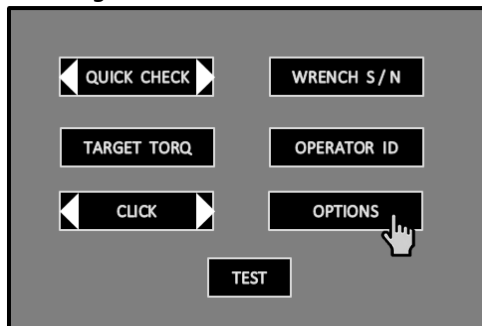

Figure 6: DTT Options Screen

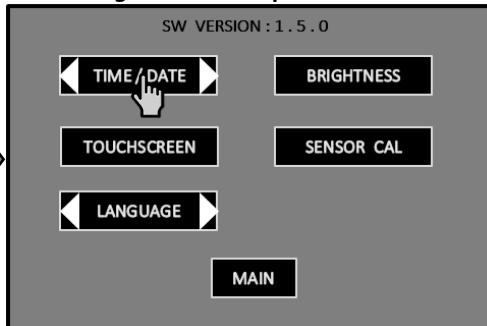
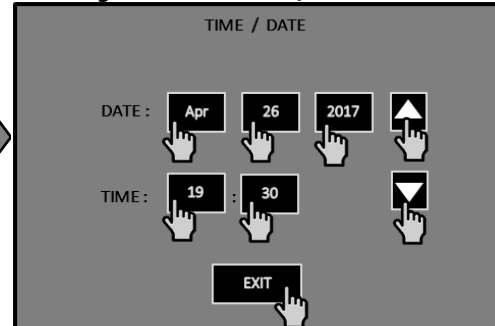

Figure 7: DTT Time / Date Screen



1. In Main Screen press “**OPTIONS**” button.
2. In Options Screen press “**TIME / DATE**” button.
3. In Time / Date Screen press “**Apr**” button to activate month selection. Press “**UP / DOWN**” buttons to select months.
 - Press “**26**” button to activate day selection. Press “**UP / DOWN**” buttons to select days.
 - Press “**2017**” button to activate month selection. Press “**UP / DOWN**” buttons to select through years.
 - Press “**19**” button to activate hour selection. Press “**UP / DOWN**” buttons to select through hours.
 - Press “**30**” button to activate minute selection. Press “**UP / DOWN**” buttons to select minutes.
 - Press “**EXIT**” button to save all time / date entries.

Note: The time / date is saved over power cycles through a lithium coin battery (3V) P/N 2344-0031-01.

The coin battery can be accessed through DTT enclosure, by removing four Phillips screws located on back plate.

Set Language and Decimal / Comma Mark

Figure 5: DTT Main Screen

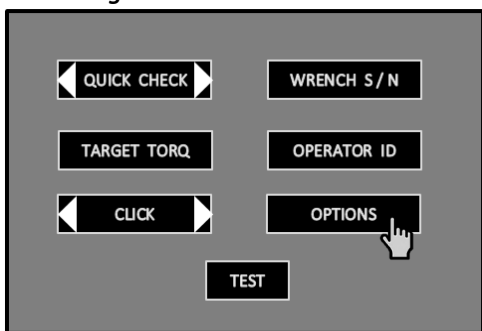

Figure 6: DTT Options Screen

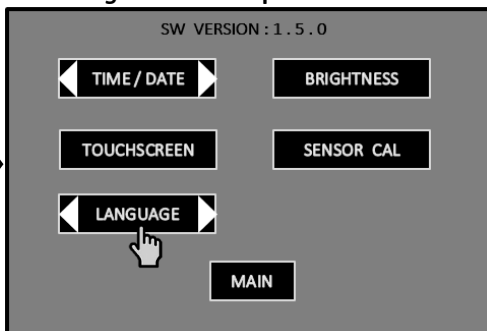

Figure 8: DTT Select Language Screen



1. In Main Screen press “**OPTIONS**” button.
2. In Options Screen press “**LANGUAGE**” button.
3. In Select Language Screen press “**ENGLISH**” button to select “**FRENCH**” or “**ENGLISH**” selections.
 - Press “**DECIMAL MARK**” button to select “**123.4**” or “**123,4**” decimal or comma separation selections.
 - Press “**SAVE**” button to accept changes or press “**CANCEL**” button to discard changes and go back to Main Screen.

Note: English is default language, and 123.4 is default decimal mark.

Touchscreen Calibration

Figure 5: DTT Main Screen

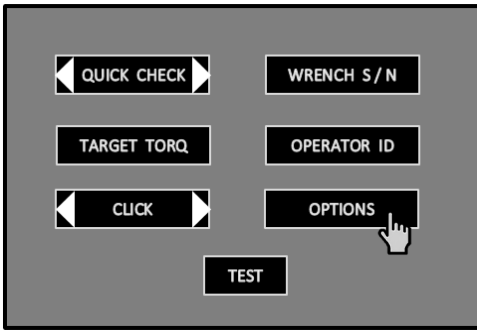

Figure 6: DTT Options Screen

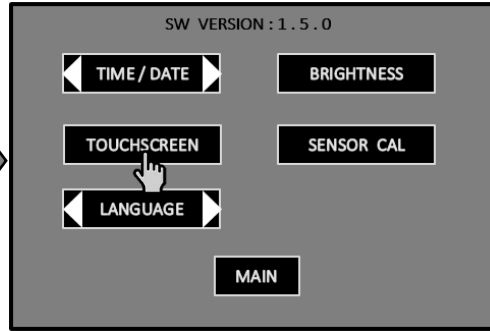
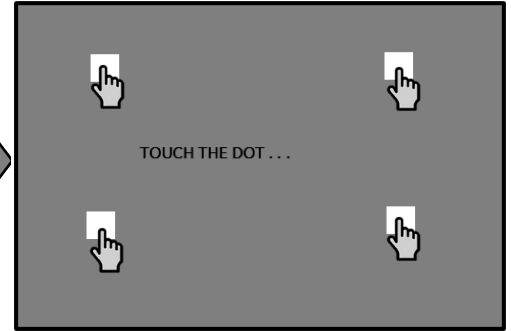

Figure 9: DTT Touch Cal Screen



1. In Main Screen press “**OPTIONS**” button.
2. In Options Screen press “**TOUCHSCREEN**” button.
3. In Touch Cal Screen press center of white squares as they appear.
4. Once all four presses of white squares are complete, the Main Screen will appear.

Note: In the event touchscreen calibration is so far off and DTT Touch Cal Screen cannot be entered. Press seven times in succession on a blank area of DTT Main Screen to re-enter DTT Touch Cal Screen process.

Set Brightness

Figure 5: DTT Main Screen

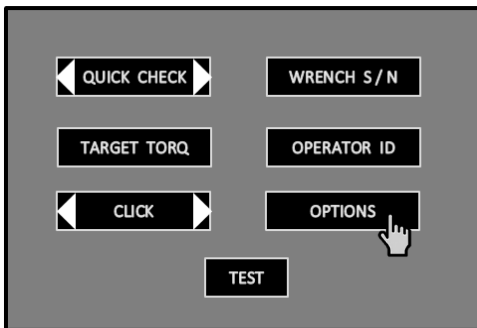

Figure 6: DTT Options Screen

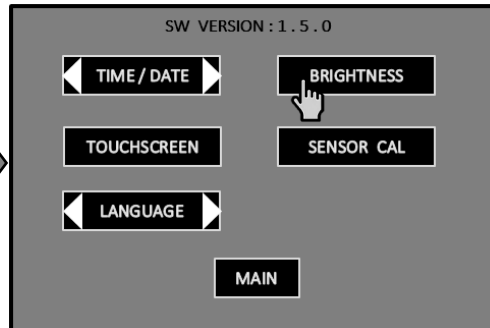

Figure 10: DTT Brightness Screen



1. In Main Screen press “**OPTIONS**” button.
2. In Options Screen press “**BRIGHTNESS**” button.
3. In Set Brightness Screen press “**UP/DOWN**” buttons to set brightness from 30 to 100.
4. Press “**EXIT**” button return to Main Screen.

Sensor Calibration

Figure 5: DTT Main Screen

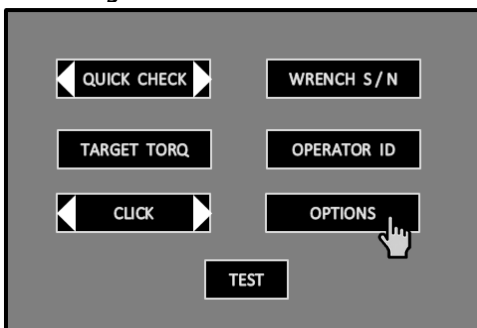
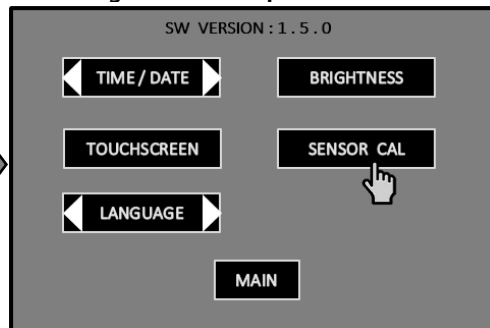

Figure 6: DTT Options Screen



Note: The DDT Calibration Manual must be used to retrieve password to enter calibration adjustment screens

Contact: 626-695-0668

Tests

Testing Torque Wrenches

IMPORTANT

- To avoid damage, be sure the DTT model being used is capable of handling the torque being applied.
- Always position a torque wrench within $\pm 15^\circ$ of perpendicular to the display housing (Figure 13).
- Apply torque at the center of torque wrench handle.
- Confirm torque wrench square drive is completely engaged to DTT transducer female square drive socket
- Confirm there is no visible damage to torque wrench.
- Confirm torque wrench ratcheting mechanism is working properly

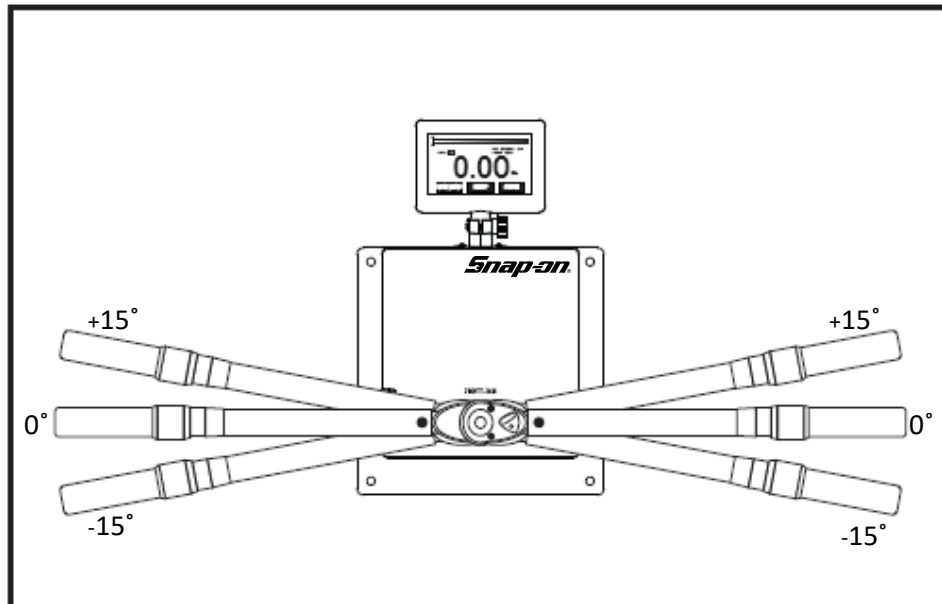

Figure 13: Torque Wrench Position, Perpendicular to Tester

1. Prepare tester for use. For additional information refer to **DTT Tester Setup** page.
2. The DTT will automatically ZEROTARE when power is switched on.
3. **DO NOT** power on DTT with a torque wrench engaged to the DTT tester transducer.

DTT Digital Torque Tester

Quick Check

Figure 5: DTT Main Screen

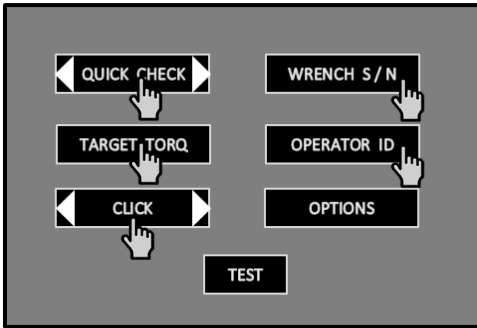

Figure 11: DTT Target Torque Screen

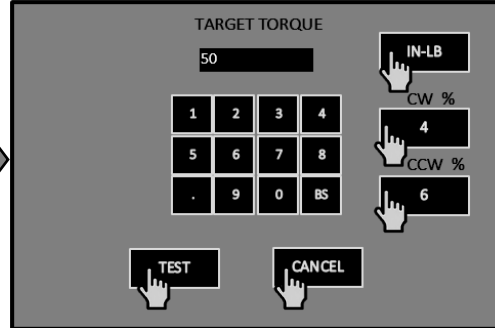
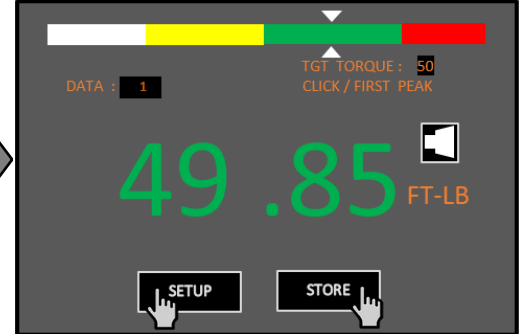

Figure 12: DTT Measurement Screen



- In Main Screen press test type button until **"QUICK CHECK"** appears.
 - When **"QUICK CHECK"** is selected **"TARGET TORQUE"** will automatically appear.
 - Press **"CLICK"** button to select torque wrench type.
 - Optional: Press **"WRENCH S/N"** to enter a 12-character alpha / numeric wrench serial number. Press **"SAVE"** button
 - Optional: Press **"OPERATOR ID"** to enter an 8-character alpha / numeric Operator ID. Press **"SAVE"** button
 - Press **"TARGET TORQUE"** button to enter Target Torque Screen.
- In Target Torque Screen press **"IN-LB"** button to select desired units.
 - Press **"CW %"** and **"CCW %"** buttons to enter a \pm tolerance from 2% to 10% of target torque.
 - Press **"TEST"** button to enter Measurement Screen and begin CW test. Or press **"CANCEL"** button to go back to Main Screen.
- In Measurement Screen press **"STORE"** button to increment data field.
- When CW test is complete apply torque in CCW direction, or press **"SETUP"** to exit to Main Screen.

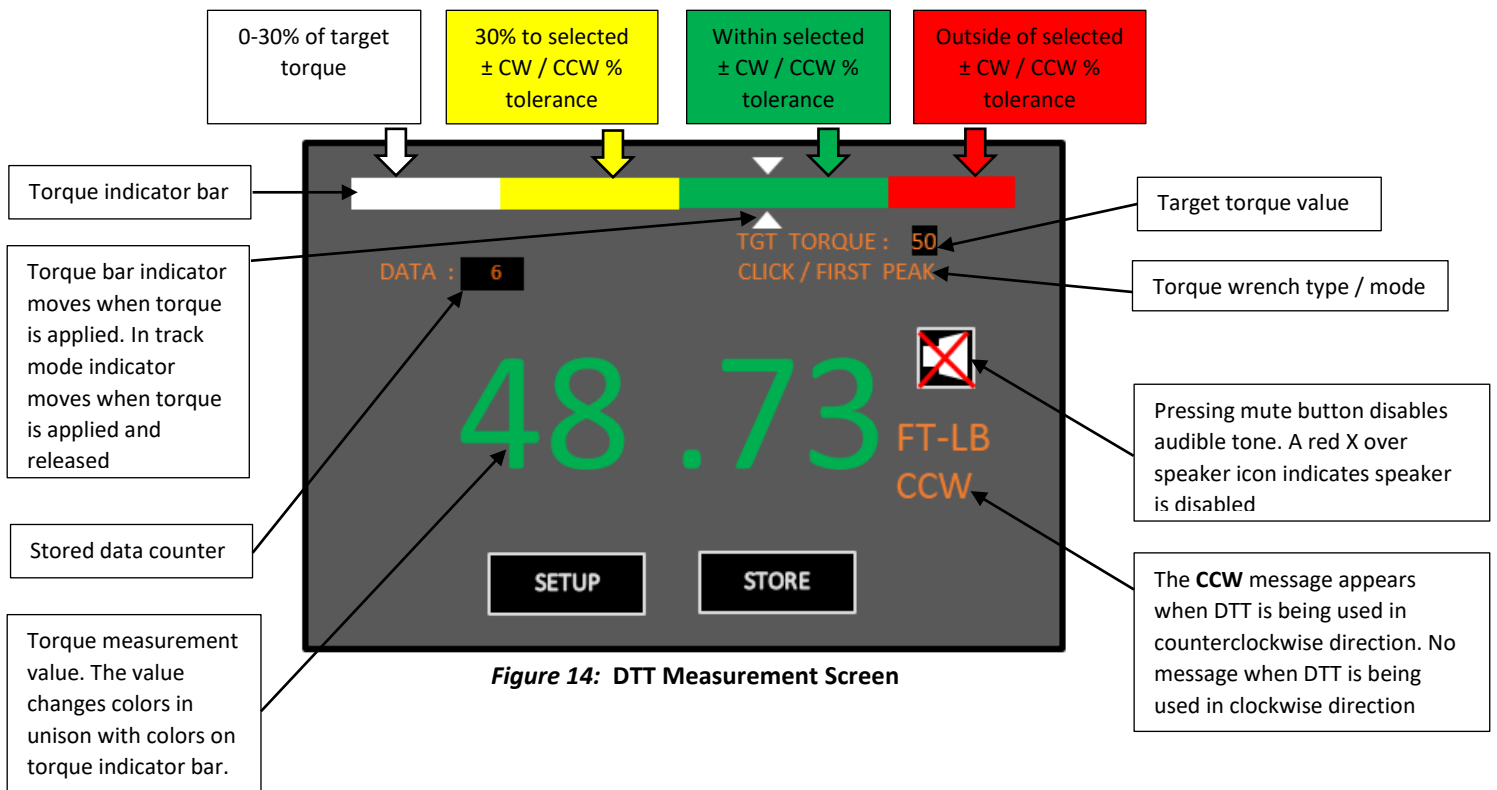

Figure 14: DTT Measurement Screen

Audit CW & CCW

Figure 15: DTT Main Screen A

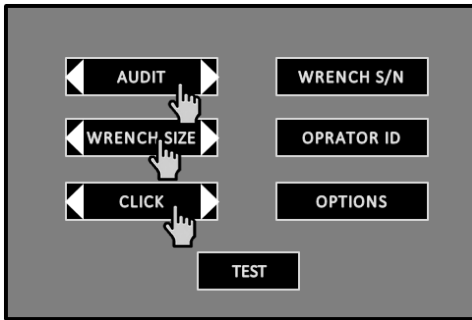

Figure 16: DTT Wrench Max Screen

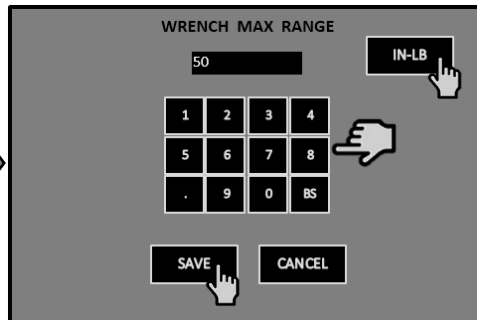

Figure 17: DTT Main Screen B

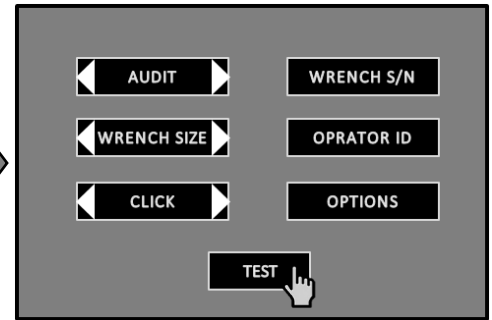

Figure 18: DTT Audit Setup Screen

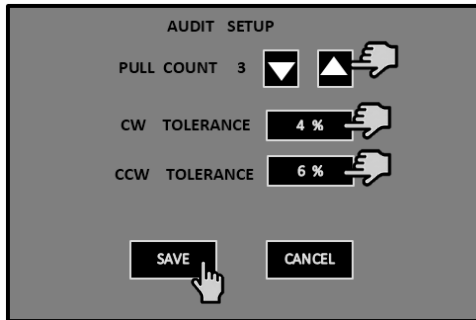

Figure 19: DTT Cycle CW Screen

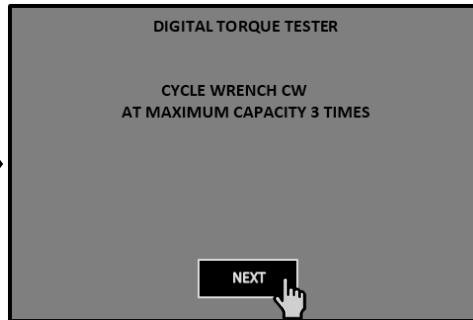
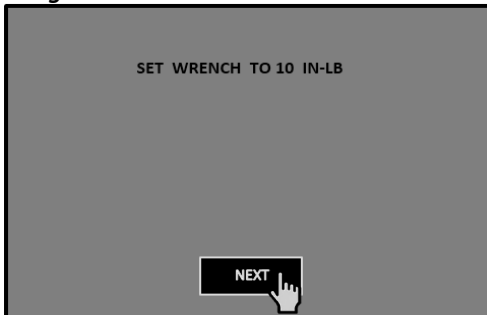

Figure 20: DTT ZEROTARE Screen



Figure 21: DTT Set Wrench 20% Screen



A 10-50 in-lbs click style torque wrench is used in this example.

1. In Main Screen A press test type button until “AUDIT” appears.
 - When “AUDIT” is selected “WRENCH SIZE” will automatically appear.
 - Press “CLICK” button to select torque wrench type.
 - Optional: Press “WRENCH S/N” to enter a 12-character alpha / numeric wrench serial number. Press “SAVE” button
 - Optional: Press “OPERATOR ID” to enter an 8-character alpha / numeric Operator ID. Press “SAVE” button
 - In Main Screen A or B press “WRENCH SIZE” button to enter Wrench Max Screen.
2. In Wrench Max Screen press “IN-LB” button to select units. Enter torque wrench max value press “SAVE” button
3. In Main Screen B press “TEST” button to enter Audit Setup Screen
4. In Audit Setup Screen press “UP/DOWN” buttons to enter torque wrench pulls from 1 to 10. (Example: 3 is pull count).
 - Press “CW %” and “CCW %” buttons to enter a ± tolerance from 2% to 10% of target torque. Press “SAVE” button
5. Follow next three screen message prompts on Figures 19, 20 and 21. (20% Test Point).

Note: Steps 6 thru 12 continued on next page

Audit CW & CCW (Cont.)

Figure 22: DTT Measurement Screen

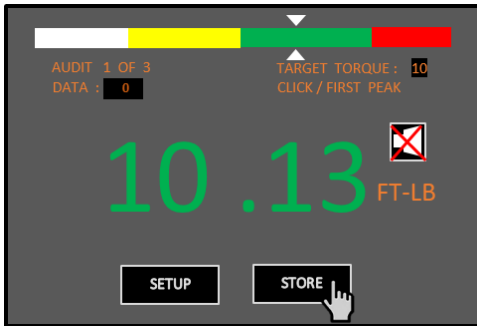

Figure 23: DTT Set Wrench 60% Screen

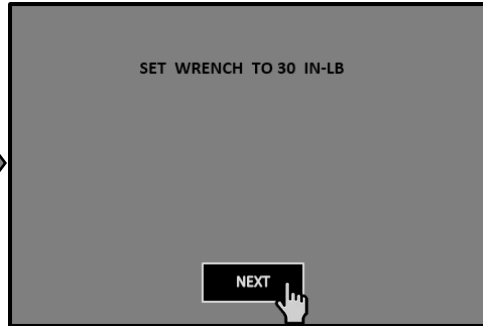

Figure 24: DTT Measurement Screen A

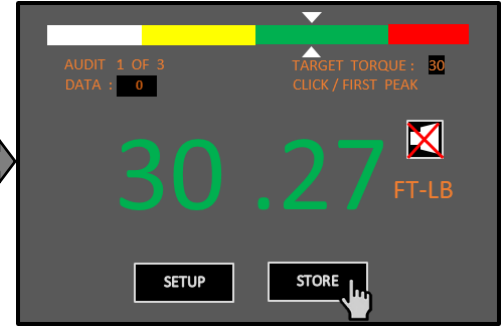

Figure 25: DTT Set Wrench 100% Screen

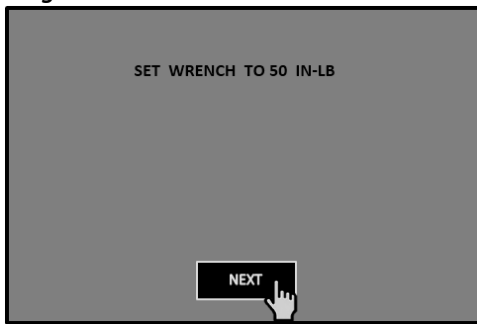

Figure 26: DTT Measurement Screen B

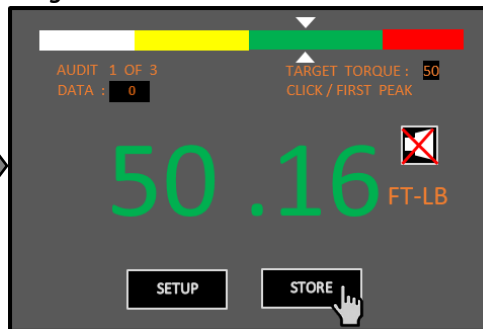
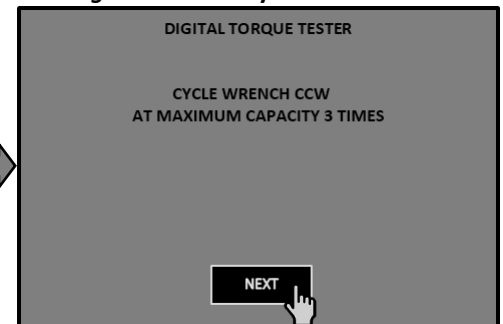

Figure 27: DTT Cycle CCW Screen



6. In Measurement Screen pull torque wrench CW until it clicks. Press "STORE" to change Audit message from 1 of 3 to 2 of 3
 - Repeat step 6 two more times to complete 20% test.
7. Follow screen message prompt in (Figure 23) and press "NEXT" button. (60% Test Point)
8. Repeat step 6 in Measurement Screen A (Figure 24).
9. Follow screen message prompt in (Figure 25) and press "NEXT" button. (100% Test Point)
10. Repeat step 6 in Measurement Screen A (Figure 26).
11. Follow screen message prompt in (Figure 27) and press "NEXT" button.
12. Repeats steps 5 thru 10 for CCW Audit Test.

Note: Test points in Audit mode are fixed at 20%, 60% and 100% and cannot be changed.

Audit CW

Figure 28: DTT Main Screen C

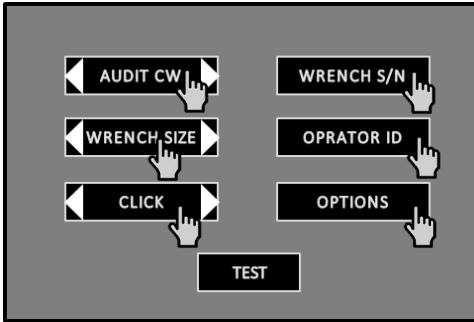

Figure 16: DTT Wrench Max Screen

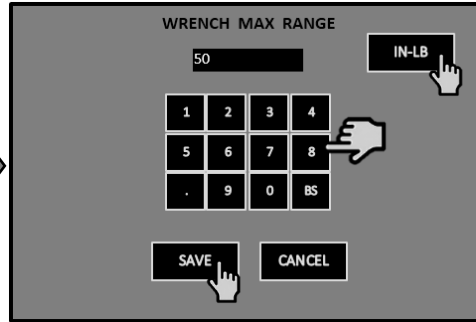

Figure 29: DTT Main Screen D

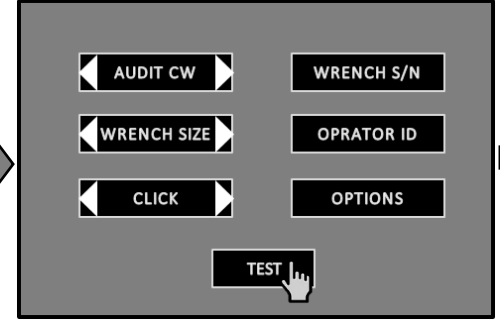

Figure 30: DTT Audit Setup Screen A

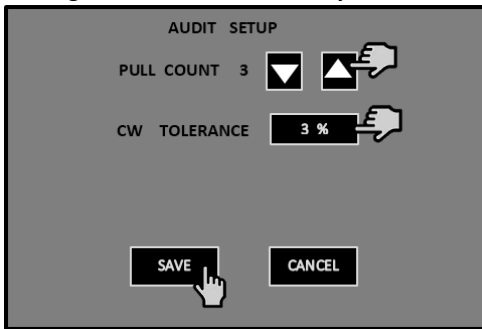

Figure 19: DTT Cycle CW Screen

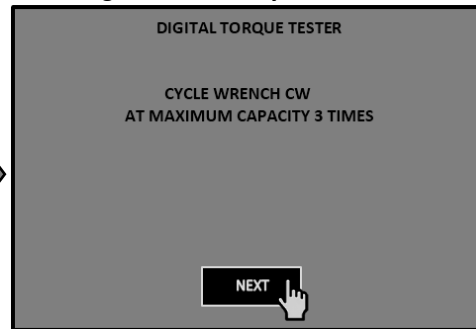
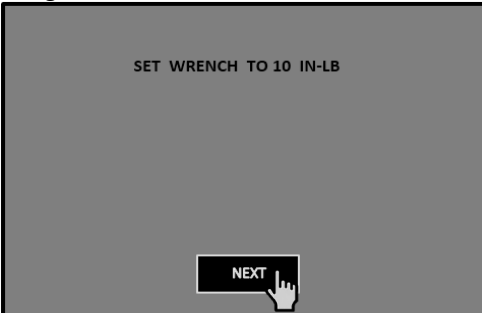

Figure 20: DTT ZEROTARE Screen



Figure 21: DTT Set Wrench 20% Screen



A 10-50 in-lbs click style torque wrench is used in this example.

1. In Main Screen C press test type button until **"AUDIT CW"** appears.
 - When **"AUDIT CW"** is selected **"WRENCH SIZE"** will automatically appear.
 - Press **"CLICK"** button to select torque wrench type.
 - Optional: Press **"WRENCH S/N"** to enter a 12-character alpha / numeric wrench serial number. Press **"SAVE"** button
 - Optional: Press **"OPERATOR ID"** to enter an 8-character alpha / numeric Operator ID. Press **"SAVE"** button
 - In Main Screen C or D press **"WRENCH SIZE"** button to enter Wrench Max Screen.
2. In Wrench Max Screen press **"IN-LB"** button to select units. Enter torque wrench max value press **"SAVE"** button
3. In Main Screen D press **"TEST"** button to enter Audit Setup Screen
4. In Audit Setup Screen press **"UP/DOWN"** buttons to enter torque wrench pulls from 1 to 10. (Example: 3 is pull count).
 - Press **"CW %"** button to enter a ± tolerance from 2% to 10% of target torque. Press **"SAVE"** button
5. Follow next three screen message prompts on Figures 19, 20 and 21. (20% Test Point).

Note: Steps 6 thru 11 continued on next page

Audit CW (Cont.)

Figure 22: DTT Measurement Screen

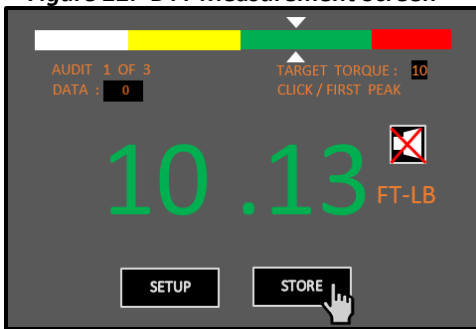

Figure 23: DTT Set Wrench 60% Screen

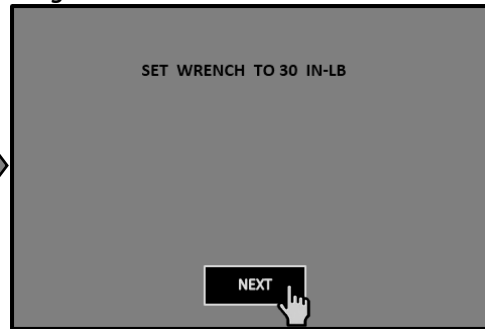

Figure 24: DTT Measurement Screen A

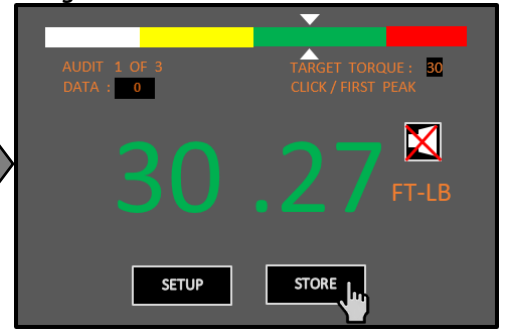

Figure 25: DTT Set Wrench 100% Screen

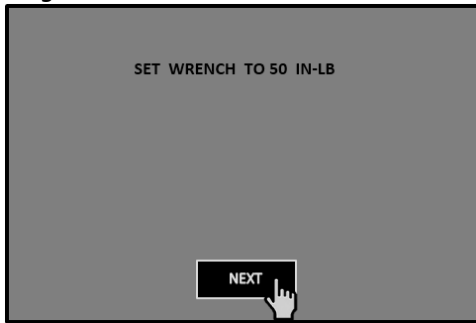
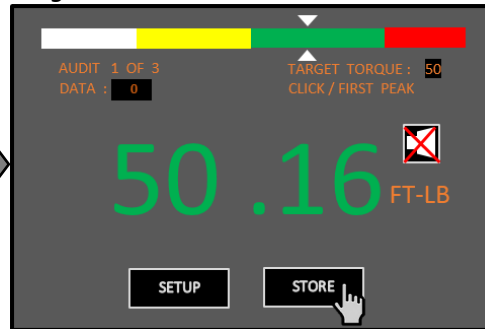

Figure 26: DTT Measurement Screen B



6. In Measurement Screen pull torque wrench CW until it clicks. Press "STORE" to change Audit message from 1 of 3 to 2 of 3
 - Repeat step 6 two more times to complete 20% test.
7. Follow screen message prompt in (Figure 23) and press "NEXT" button. (60% Test Point)
8. Repeat step 6 in Measurement Screen A (Figure 24).
9. Follow screen message prompt in (Figure 25) and press "NEXT" button. (100% Test Point)
10. Repeat step 6 in Measurement Screen B (Figure 26).
11. DTT returns to Main Screen.

Note: Test points in CW Audit mode are fixed at 20%, 60% and 100% and cannot be changed.

Audit CCW

Figure 31: DTT Main Screen E

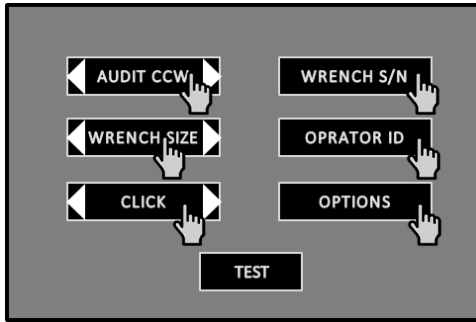

Figure 16: DTT Wrench Max Screen

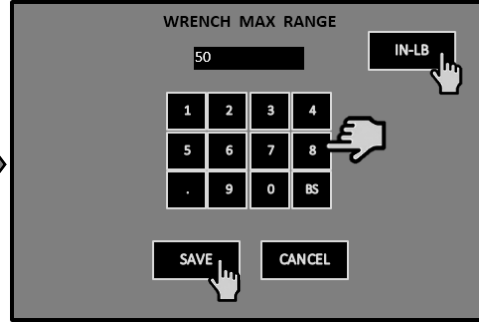

Figure 32: DTT Main Screen F

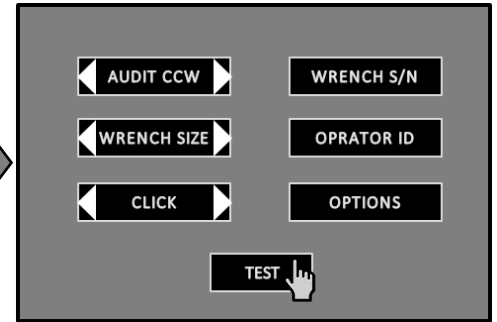

Figure 33: DTT Audit Setup Screen B



Figure 27: DTT Cycle CCW Screen



Figure 20: DTT ZEROTARE Screen



Figure 21: DTT Set Wrench 20% Screen

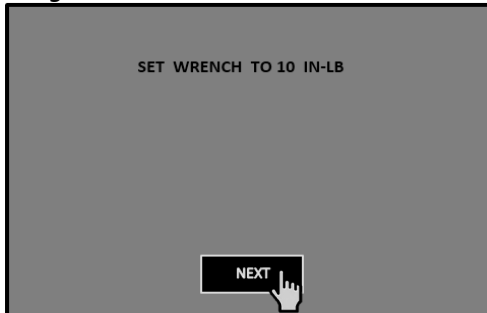

A 10-50 in-lbs click style torque wrench is used in this example.

1. In Main Screen C press test type button until **"AUDIT CCW"** appears.
 - When **"AUDIT CCW"** is selected **"WRENCH SIZE"** will automatically appear.
 - Press **"CLICK"** button to select torque wrench type.
 - Optional: Press **"WRENCH S/N"** to enter a 12-character alpha / numeric wrench serial number. Press **"SAVE"** button
 - Optional: Press **"OPERATOR ID"** to enter an 8-character alpha / numeric Operator ID. Press **"SAVE"** button
 - In Main Screen E or F press **"WRENCH SIZE"** button to enter Wrench Max Screen.
2. In Wrench Max Screen press **"IN-LB"** button to select units. Enter torque wrench max value press **"SAVE"** button
3. In Main Screen F press **"TEST"** button to enter Audit Setup Screen B
4. In Audit Setup Screen press **"UP/DOWN"** buttons to enter torque wrench pulls from 1 to 10. (Example: 3 is pull count).
 - Press **"CCW %"** button to enter a ± tolerance from 2% to 10% of target torque. Press **"SAVE"** button
5. Follow next three screen message prompts on Figures 27, 20 and 21. (20% Test Point).

Note: Steps 6 thru 11 continued on next page

Audit CCW (Cont.)

Figure 34: DTT Measurement Screen C

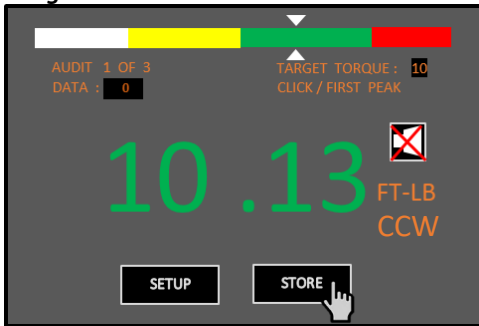

Figure 23: DTT Set Wrench 60% Screen

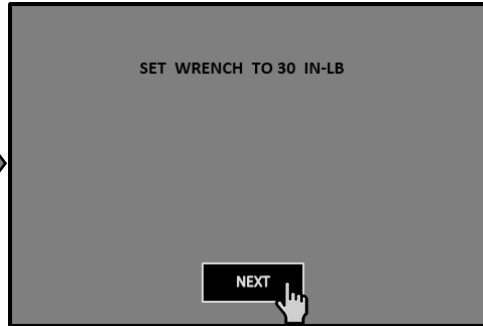

Figure 35: DTT Measurement Screen D

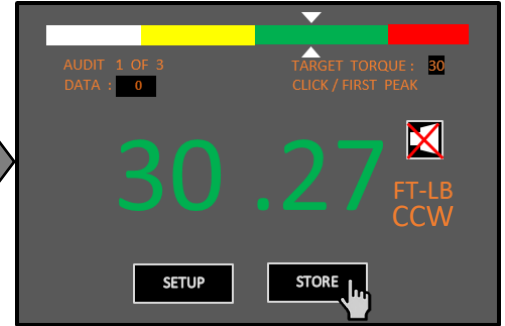

Figure 25: DTT Set Wrench 100% Screen

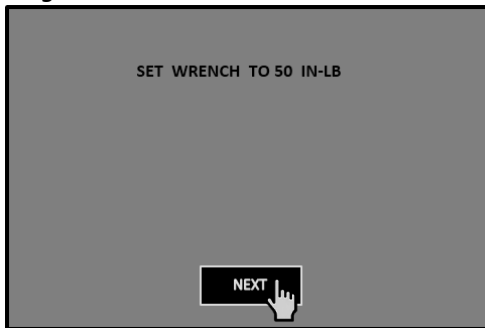
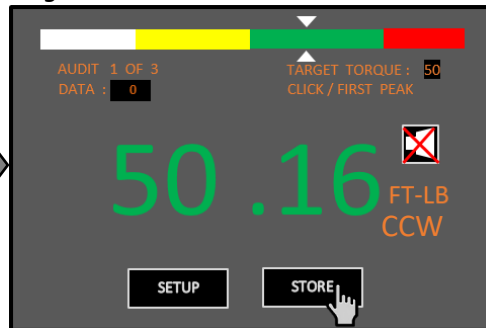

Figure 36: DTT Measurement Screen F



1. In Measurement Screen C pull torque wrench CCW until it clicks. Press “STORE” to change Audit message from 1 of 3 to 2 of 3
➤ Repeat step 6 two more times to complete 20% test.
2. Follow screen message prompt in (Figure 23) and press “NEXT” button. (60% Test Point)
3. Repeat step 6 in Measurement Screen D (Figure 35).
4. Follow screen message prompt in (Figure 25) and press “NEXT” button. (100% Test Point)
5. Repeat step 6 in Measurement Screen F (Figure 36).
6. DTT returns to Main Screen.

Note: Test points in CCW Audit mode are fixed at 20%, 60% and 100% and cannot be changed.

Data Offload (Win10 and earlier)

Torque measurements are stored in the internal memory every time the STORE button is pressed during the testing procedure.

DTT tester allows users to offload saved data to a PC via the USB cable. Users can also send individual torque results.

DTT stores up to 5000 peak torque events

Figure 37: PC Offload Folder

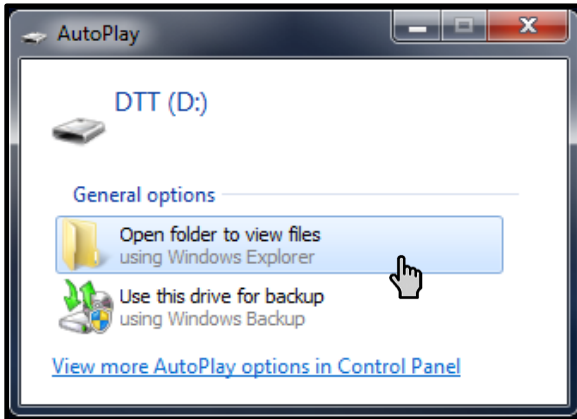

Excel Spreadsheet contains below:

- TIME
 - DATE
 - OPERATOR ID
 - WRENCH SERIAL NUMBER
 - ACTUAL TORQUE
 - TARGET TORQUE
 - UNITS
 - ERROR (%)
 - RESULT: PASS / FAIL (Previous overtorque detected)
- Note: The "Previous overtorque detected" message will show in the Results column if a 125% of rated capacity is applied on the transducer shown in Figure 39a..*

Figure 38: PC Offload File

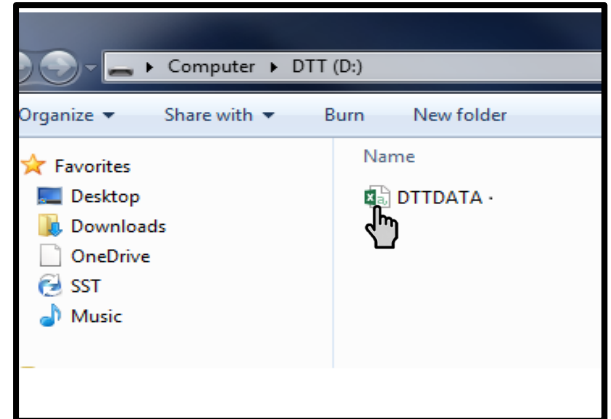

Figure 39a: PC Offload Spreadsheet

Figure 39: PC Offload Spreadsheet

TIME	DATE	OPERATOR ID	WRENCH S/N	ACT TORQUE	TGT TORQUE	UNITS	ERR(%)	RESULT
11:29:52	02/26/09	00000000	15478999	51.62	50	IN-OZ	3.24	PASS - Previous overtorque detected
11:29:46	02/26/09	00000000	15478999	49.94	50	IN-OZ	-0.12	PASS - Previous overtorque detected
11:29:11	02/26/09	00000000	15478999	51.2	50	IN-OZ	2.4	PASS - Previous overtorque detected
11:28:59	02/26/09	00000000	15478999	48.36	50	IN-OZ	-3.28	PASS - Previous overtorque detected
11:27:57	02/26/09	00000000	15478999	48.99	50	IN-OZ	-2.02	PASS - Previous overtorque detected
11:27:52	02/26/09	00000000	15478999	48.91	50	IN-OZ	-2.18	PASS - Previous overtorque detected
11:27:48	02/26/09	00000000	15478999	51.35	50	IN-OZ	2.7	PASS - Previous overtorque detected
11:27:44	02/26/09	00000000	15478999	49.41	50	IN-OZ	-1.19	PASS - Previous overtorque detected

ERR(%)	RESULT
3.24	PASS - Previous overtorque detected
-0.12	PASS - Previous overtorque detected
2.4	PASS - Previous overtorque detected
-3.28	PASS - Previous overtorque detected
-2.02	PASS - Previous overtorque detected
-2.18	PASS - Previous overtorque detected
2.7	PASS - Previous overtorque detected
-1.19	PASS - Previous overtorque detected

To retrieve stored data from DTT:

1. Power on DTT
2. Connect USB cable between DTT and PC USB ports.
3. On the PC, double click DTTDATA.CSV file located in MY COMPUTER \ DTT. (Fig.37)
4. Click on DTTDATA file. (Fig. 38)
5. Excel Spreadsheet file will contain following information on (Fig. 39).
6. Save file as needed or delete DTTDATA file shown in folder (Fig. 38).
7. DTT stores up to 5000 torque events.

Note: Stored data cannot be deleted directly from DTT Tester.

Note*: Download all stored DTT data to the PC before powering off DTT Tester.

Note:** To Delete all stored data right click icon and select delete shown on Figure 38.

Data Offload (Single Steam) (Win10 and earlier)

DTT tester allows users to offload saved data to a PC via the USB cable. User can also send individual torque results instantaneously to a Word, Notepad or Excel spreadsheets.

In the below example an Excel spreadsheet will be used

Excel Spreadsheet contains below:

TIME
DATE
OPERATOR ID
WRENCH SERIAL NUMBER
ACTUAL TORQUE
TARGET TORQUE
UNITS
ERROR (%)
RESULT: PASS / FAIL (Previous overtorque detected)
Note: The "Previous overtorque detected" message will show in the Results column if a 125% of rated capacity is applied on the transducer.

Figure 40: PC Offload Spreadsheet A

	A	B	C	D	E	F	G	H	I	J
1	9:58:03	02/27/09	12ASDF	123456789012	48.29	50	IN-LB	-3.43	PASS	
2	9:58:07	02/27/09	12ASDF	123456789012	49.74	50	IN-LB	-0.53	PASS	
3	9:58:13	02/27/09	12ASDF	123456789012	50.7	50	IN-LB	1.4	PASS	
4										
5										
6										
7										
8										
9										

To send single streams of data from DTT to PC:

1. Power on DTT
2. Connect the USB cable between DTT and PC USB ports.
3. Any DTT Test Mode can be used: AUDIT, AUDIT CW, AUDIT CCW and QUICK CHECK
4. Open a blank Word, Notepad or Excel Worksheet and click on open cell. (Fig 40)
 - The information sent from DTT will appear in the open cell chosen.
5. When a peak torque is reached, press **"STORE"** button on DTT Measurement Screen (Fig.36).
6. Save file as needed or delete DTTDATA file shown in folder (Fig. 38).
7. DTT stores up to 5000 torque events.

Note: Stored data cannot be deleted directly from DTT Tester.

Note*: Download all stored DTT data to the PC before powering off DTT Tester.

Data Offload (Win11)

Figure 41: PC

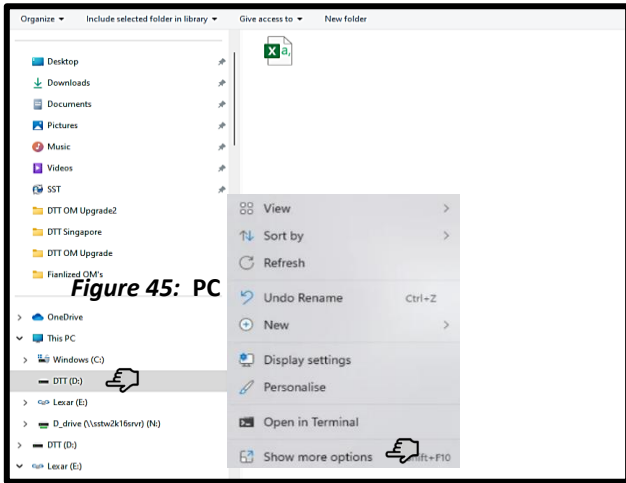

Figure 42: PC

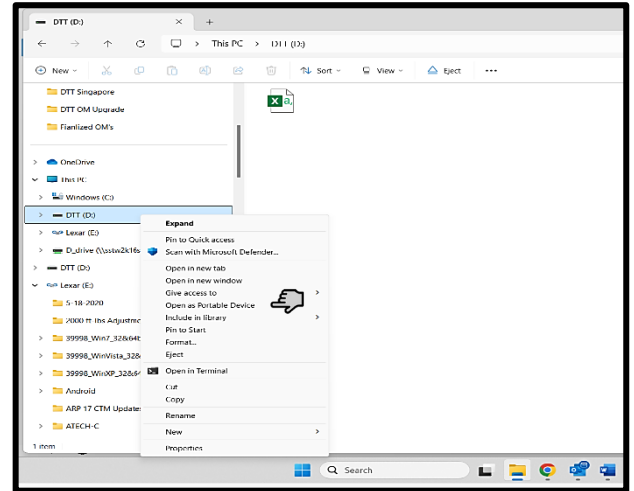

Figure 43: PC

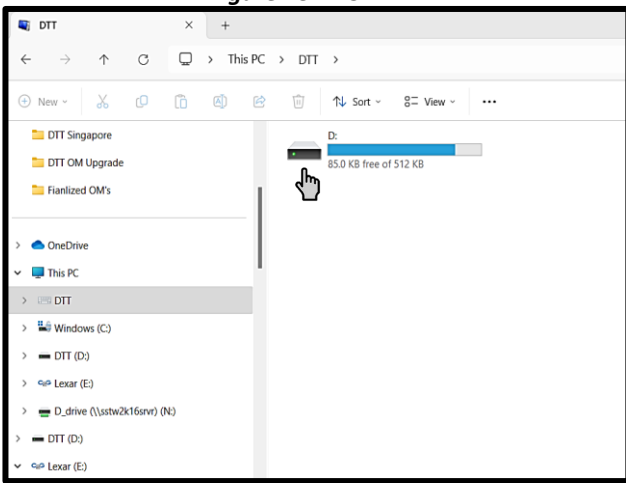

Figure 44: PC

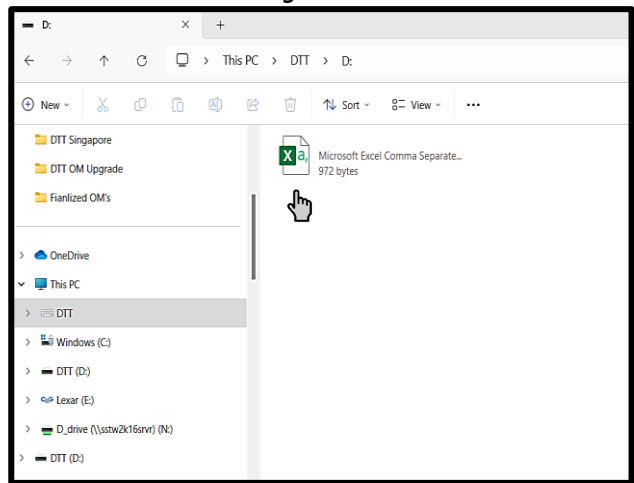

Figure 45: PC

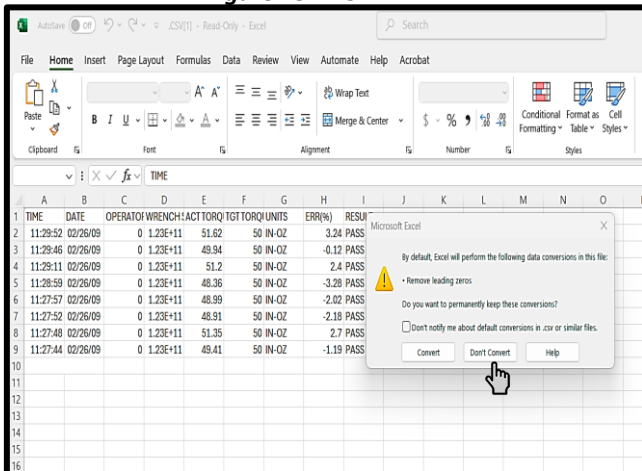

Figure 46: PC

TIME	DATE	OPERATORID	WRENCHSN	ACTTORQUE	TGTTORQUE	UNITS	ERR(%)	RESULT	DTTTESTERSTATUS
1	11:29:52	02/26/09	0	1.23457E+11	51.62	50 IN-OZ	3.24	PASS	OK
2	11:29:46	02/26/09	0	1.23457E+11	49.94	50 IN-OZ	-0.12	PASS	OK
3	11:28:11	02/26/09	0	1.23E+11	51.2	50 IN-OZ	2.4	PASS	OK
4	11:28:59	02/26/09	0	1.23E+11	48.36	50 IN-OZ	-3.28	PASS	OK
5	11:27:57	02/26/09	0	1.23E+11	48.99	50 IN-OZ	-2.02	PASS	OK
6	11:27:52	02/26/09	0	1.23E+11	48.91	50 IN-OZ	-2.18	PASS	OK
7	11:27:48	02/26/09	0	1.23E+11	51.35	50 IN-OZ	2.7	PASS	OK
8	11:27:44	02/26/09	0	1.23E+11	49.41	50 IN-OZ	-1.19	PASS	OK

To send single streams of data from DTT to PC:

1. Power on DTT
2. Connect the USB cable between DTT and PC USB ports.
3. Select the upper "DTT (D:)" and right click and select "Show more options" shown on Figure 41.
4. Select "Open as Portable Device" shown on Figure 42.
5. Click on D: icon shown on Figure 43.
6. Click on "Xa" icon shown on Figure 44.
7. Spread Sheet opens, click "Don't Convert" shown on Figure 45.
8. DTT Spread Sheet is ready, shown on Figure 46

DTT “OVERTORQUE” Message 110% - 124% of Scale

Figure 47: DTT Screen



Figure 48: DTT Screen

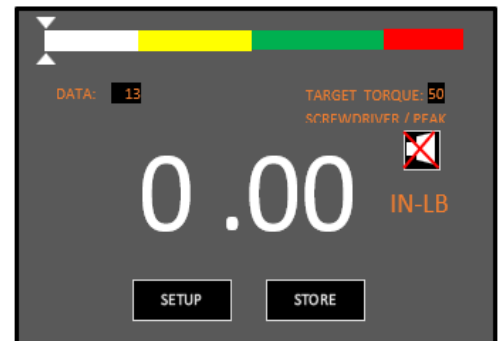

1. A successive audible beep with same frequency when in the red bar area.
2. The “WARNING – SENSOR OVERTORQUE DETECTED!” message appears at the bottom of the screen, shown on Figure 47.
3. The “WARNING – SENSOR OVERTORQUE DETECTED!” message will disappear if a subsequent torque is applied, or the STORE button is pressed in the DTT Main Measurement Screen shown on Figure 47.
4. The “WARNING – SENSOR OVERTORQUE DETECTED!” removed from DTT Main Measurement Screen shown on Figure 48

DTT “OVERTORQUE” Message 125% of Scale

Figure 49: DTT Screen

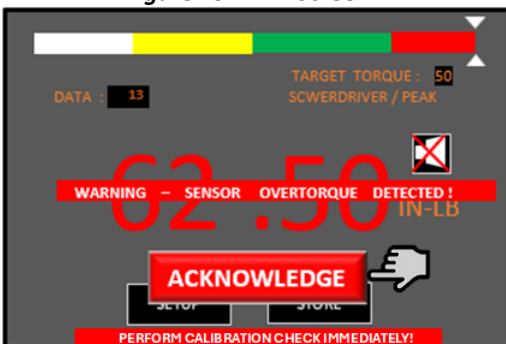
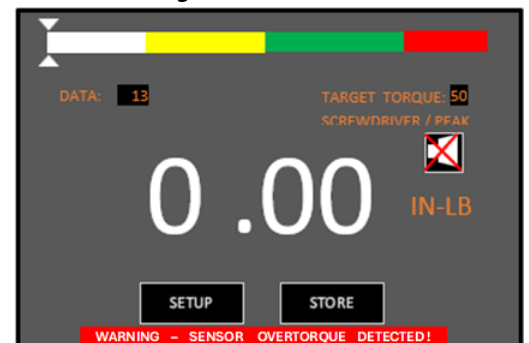

Figure 50: DTT Screen



1. A successive audible beep with same frequency when in the red bar area.
2. The “WARNING – SENSOR OVER TORQUE DETECTED” / “PERFORM CALIBRATION CHECK IMMEDIATELY” messages and ACKNOWLEDGE button appears. The numerical peak torque value will continue to accumulate until force is no longer applied, shown on Figure 49.
3. When force is no longer applied, the “WARNING – SENSOR OVERTORQUE DETECTED” / “PERFORM CALIBRATION CHECK IMMEDIATELY” messages, and “ACKNOWLEDGE” button and peak over torque value will freeze / lockout on the DTT Main Measurement Screen shown on Figure 49.
4. The “ACKNOWLEDGE” button must be pressed to unfreeze / unlock the DTT Screen in the Main Measurement Screen shown on Figure 49.
5. The “WARNING – SENSOR OVERTORQUE DETECTED! Message will remain at the bottom of the Main Measurement Screen and all DTT Menu Screens shown of Figure 50.
6. In the stored results data file a

NOTE: The “WARNING – SENSOR OVERTORQUE DETECTED” message can only be removed in the “CAL CHECK” menu after confirming the DTT is within the $\pm 0.5\%$ Accuracy of indicated Test Value (AT ALL TEST POINTS). See DTT Calibration Manual.

Note*: DTT offload page will have a column that reads “Previous overtorque detected.”

Note:** Messages CANNOT be overridden through DTT power cycles.

CE DECLARATION OF CONFORMITY

Manufacturer:

**Snap-on Specialty Tools
19220 San Jose AVE
City of Industry, CA 91748**

Product: Digital Torque Tester

Type: Type II, Class B Digital Torque Testing Equipment

Model No: QC1DTT10 / QC2DTT250 / QC2DTT1000 / QC3DTT250 / QC4DTT600

Serial No: -

Complies with the requirements of the following European Directives:

Machinery Directive: 2006/42/EC

Electromagnetic Compatibility Directive: 2004/108/EC

Main Standards Considered:

EN 12100-1:2003, EN12100-2:2003, EN 60204-1:2006, EN61000-6-2:2006, EN61000-6-4:2007

Company Authorized to Compile the Technical File:

**Snap-on Tools Company
2801 80th Street
Kenosha, WI 53141-1410, U.S.A.**

The authorized representative located within the community is:

**Matthew Law
Snap-on Tools LTD.
Telford Way Industrial Estate
Kettering, Northants
NN16 8SN
United Kingdom**

Signature: 

**Engineering Manager: Tim Tomlinson
Snap-on Specialty Tools
19220 San Jose AVE
City of Industry CA, 91748
January 2012**

For Warranty Claims, Contact Snap-on Tools

LIMITED WARRANTY

The DTT is backed by a one-year warranty. This warranty covers manufacturer defects and workmanship. The warranty excludes misuse, abuse and normal wear and tear. Exclusion is not allowed in some states and may not apply. This warranty gives you specific legal rights, and you may have other rights, which vary from state to state.

IMPORTANT ENVIRONMENTAL NOTES:



1. THIS EQUIPMENT MAY CONTAIN HAZARDOUS MATERIALS WHICH CAN BE HARMFUL TO THE ENVIRONMENT.
2. DO NOT DISPOSE OF THIS EQUIPMENT AS MUNICIPAL WASTE. RETURN IT TO DISTRIBUTOR OR A DESIGNATED COLLECTION CENTER

THANK YOU FOR CARING ABOUT OUR ENVIRONMENT!

Snap-on[®]

Snap-on Specialty Tools
19220 San Jose AVE
City of Industry, CA 91748
Phone: 626-965-0668
Fax: 626-965-2410
Email: sales@cditorque.com
Website: www.cditorque.com

Made in USA with US and Global Components

FORM ZDTT
REV D
2025-05