





Blue-Point®



Operator Instructions Includes – Foreseen Use, Work Stations, Putting Into Service, Operating, Dismantling, Assembly and Safety Rules.		Important Read these instructions carefully before installing, operating, servicing or repairing this tool. Keep these instructions in a safe accessible place.	
Manufacturer/Supplier Snap-on Tools Company 2801 80th Street Kenosha WI 53141-1410 U.S.A.		Product Type 1/8" (3 mm) Air Pencil Die Grinder	Max. RPM 75,600 Cycles Per Min. 
		Model No/Nos AT1070A	Serial No.
Product Net Weight 0.44 lbs 0.20 Kg	Recommended Use Of Balancer Or Support NO	Recommended Hose Bore Size – Minimum 5/16 Ins 8 M/M	Recommended Max. Hose Length 30 Ft 10 M
Air Pressure Recommended Working Maximum 6.2 bar 90 PSI 6.2 bar 90 PSI		Noise Level: Sound Pressure Level 79.1 dB(A) Uncertainty, K 3 dB(A) Sound Power Level 90.1 dB(A) Uncertainty, K 3 dB(A) Test Method: Tested in accordance with Pneurop test code PN8NTC1 and ISO 15744:2002	
SAFETY MESSAGES Personal Safety Equipment Use – Safety Glasses YES Use – Safety Gloves YES Use – Safety Boots Use – Breathing Masks YES Use – Ear Protectors YES	WARNING  Always Read Instructions Before Using Power Tools  Always Wear Safety Goggles  Wear Hearing Protection  Avoid Prolonged Exposure To Vibration	Vibration Level 2.37 Meters / Sec² Uncertainty, K 0.70 Meters / Sec² Test Method: Tested in accordance with ISO standards 28927-12:2012	

Safety rules when using an AT1070A Die Grinder

- Use accessories rated at least 75,600RPM.
- Prolonged exposure to vibration may cause injury.
- Read all instructions before using this tool. All operators must be fully trained in its use and aware of these safety rules.
- Do not exceed the maximum working air pressure.
- Use personal protection equipment as recommended.
- Some dust created by power sanding, sawing, grinding, drilling, and other construction activities contains chemicals known to cause cancer, birth defects and other reproductive harm.
- Use only compressed air at the recommended conditions.
- If the tool appears to malfunction, remove from use immediately and arrange for service and repair. If it is not practical to remove tool from service, then shut off the air supply to the tool and write or have written a warning note and attach it to the tool.
- If tool is to be used with a balancer or other suspension device, ensure that the tool is firmly attached to the suspension/support device.
- When operating the tool, always keep the body and particularly the hands away from the working attachment fixed to the tool.

- The tool is not electrically insulated. Never use the tool if there is any chance of coming into contact with live electricity.
- Always when using the tool, adopt a firm footing and/or position and grip the tool sufficiently only to overcome any reaction forces that may result from the tool doing work. Do not overgrip.
- Use only correct spare parts for maintenance and repair. Do not improvise or make temporary repairs. Major servicing and repairs should only be carried out by persons trained to do so.
- Do not lock, tape, wire, etc. the 'On/Off' valve in 'On' position. The trigger/lever, etc. must always be free to return to the 'Off' position when released.
- Always shut off the air supply to the tool and press the

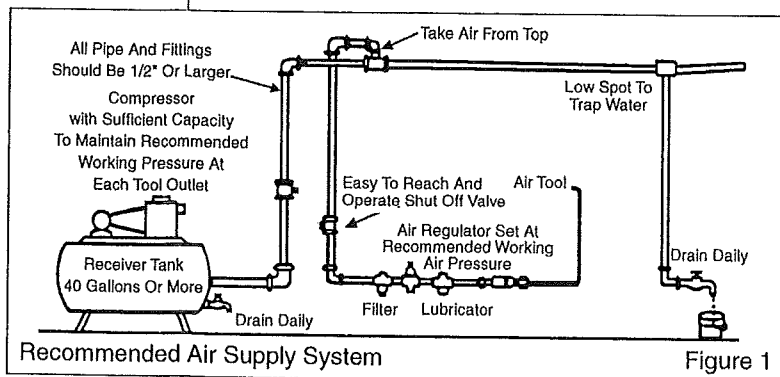

'On/Off' valve to exhaust the air from the feed hose before fitting, removing or adjusting the working attachment fitted to the tool.

- Before using the tool, make sure that a shut off device has been fitted to the air supply line and the position is known and easily accessible so that the air supply to the tool can be shut off in an emergency.
- Check hose and fittings regularly for wear.
- Take care against entanglement of the moving parts of the tool with clothing, hair, ties, cleaning rags, rings, jewelry, watches, bracelets, etc. This could cause the body or parts of the body to be drawn towards and in contact with the moving parts of the tool and could be very dangerous.
- It is expected that users will adopt safe working practices and observe all local, regional and country legal requirements when installing, using or maintaining the tool.
- Take care that the exhaust air does not point towards any other person or material or substance that could be contaminated by oil droplets. When first lubricating a tool or if the tool exhaust has a high oil content, do not allow the exhaust air to come near very hot surfaces or flames.
- Never lay the tool down until the working attachment has stopped moving.
- When the tool is not in use, shut off the air supply and press the trigger/lever to drain the supply line. If the tool is not to be used for a period of time, first lubricate, disconnect from air supply and store in a dry average room temperature environment.
- If the tool is passed from one user to a new or inexperienced user, make sure these instructions are passed with the tool.
- Do not remove any manufacturer fitted safety devices where fitted, i.e., wheel guards, safety trigger, speed governors, etc.
- Wherever possible, secure workpiece with clamps, a vise, etc. to make it rigid so it does not move during the work operation. Keep good balance at all times. Do not stretch or overreach.
- Try to match the tool to the work operation. Do not use a tool that is too light or heavy for the work operation. If in doubt, seek advice.
- In general terms, this tool is not suitable for underwater use or use in explosive environments — seek advice from manufacturer.
- Try to make sure that the work area is clear to enable the work task to be performed safely. If practical and possible, try to clear unnecessary obstructions before starting work.
- Always use air hose and couplings with minimum working pressure ratings at least 1 1/2 times the maximum working pressure rating of the tool.

Foreseen Use Of The Tool – AT1070A

This die grinder is primarily designed for use with bonded abrasive mounted point grinding wheels. It may also be used with steel rotary files and carbide burrs provided their speed rating matches or exceeds the speed of the grinder.

This tool should not be fitted with cutting off wheels, saw blades, drill bits, etc. If there is any doubt about the correct use of this product contact your supplier for advice.

Also, make sure that the shank size of the attachment to be driven matches the collet size fitted in the grinder and that the maximum allowed running speed of the attachment exceeds that marked on the grinder.

There are special rules governing the use of bonded abrasive mounted point grinding wheels – for details see section "Operating".

Work Stations

The tool should only be used as a handheld, hand operated tool. It is always recommended that the tool is used when standing on a solid floor. It can be used in other positions, but before any such use, the operator must be in a secure position having a firm grip and footing and be aware of the extra safety precautions that must be observed when using grinding machines.

Putting Into Service

Air Supply

Use a clean lubricated air supply that will give a measured air pressure at the tool of 90 p.s.i./6.2 bar when the tool is running with the air regulator fully open. Use recommended hose size and length. It is recommended that the tool is connected to the air supply as shown in figure 1. Do not connect the tool to the air line system without incorporating an easy to reach and operate air shut off valve. The air supply should be lubricated. It is strongly recommended that an air filter, regulator, lubricator (FRL) is used as shown in Figure 1 as this will supply clean, lubricated air at the correct pressure to the tool. Details of such equipment can be obtained from your supplier. If such equipment is not used, then the tool should be lubricated by shutting off the air supply to the tool, depressurizing the line by opening the air regulator on the tool. Disconnect the air line and pour into the hose adaptor a teaspoonful (5ml) of a suitable pneumatic motor lubricating oil preferably incorporating a rust inhibitor. Reconnect tool to air supply and run tool slowly for a few seconds to allow air to circulate the oil. If tool is used frequently, lubricate on daily basis and if tool starts to slow or lose power.

It is recommended that the air pressure at the tool while the tool is running is 90 psi/6.2 bar.

Operating

Select a suitable mounted point that has a free running speed higher than the maximum running speed marked on the tool.

Always match correctly the shank size to the collet size. If uncertain, have parts measured by a competent person.

Push the shank as far as possible into the collet and tighten the collet nut using the spanners provided on the collet nut and the output spindle. The shank of the mounted point may be pulled toward from the maximum insertion length, but always ensure a maximum gripping length of not less than 10 mm – see Figure 2.

Be aware that the allowed running speed of the mounted point is lowered because of an increase in the length of the shank between

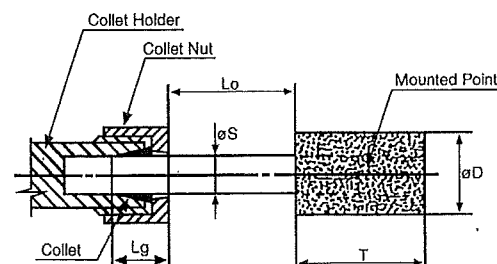

D = diameter of mounted point S = diameter of shank
T = length of mounted point Lg = gripping length
Lo = overhang

Figure 2. Gripping length of collet and chuck

the end of the collet and the body of the mounted point. This distance is shown in Figure 2. as "Lo" and is called the overhang. The information with respect to mounted point, permissible running speed and reduction in running speed due to an increase in overhang is available from the supplier of the mounted points.

If the increase in overhang for access reasons takes the permissible running speed of the mounted point below the free running speed of the grinder, select a smaller diameter mounted point.

The fitting of the mounted point should be done by a trained operator. When first starting the grinder with a new point or wheel fitted, the grinder should not be near other persons and be held in a protected area. i.e. under a bench, and run for a few seconds. This

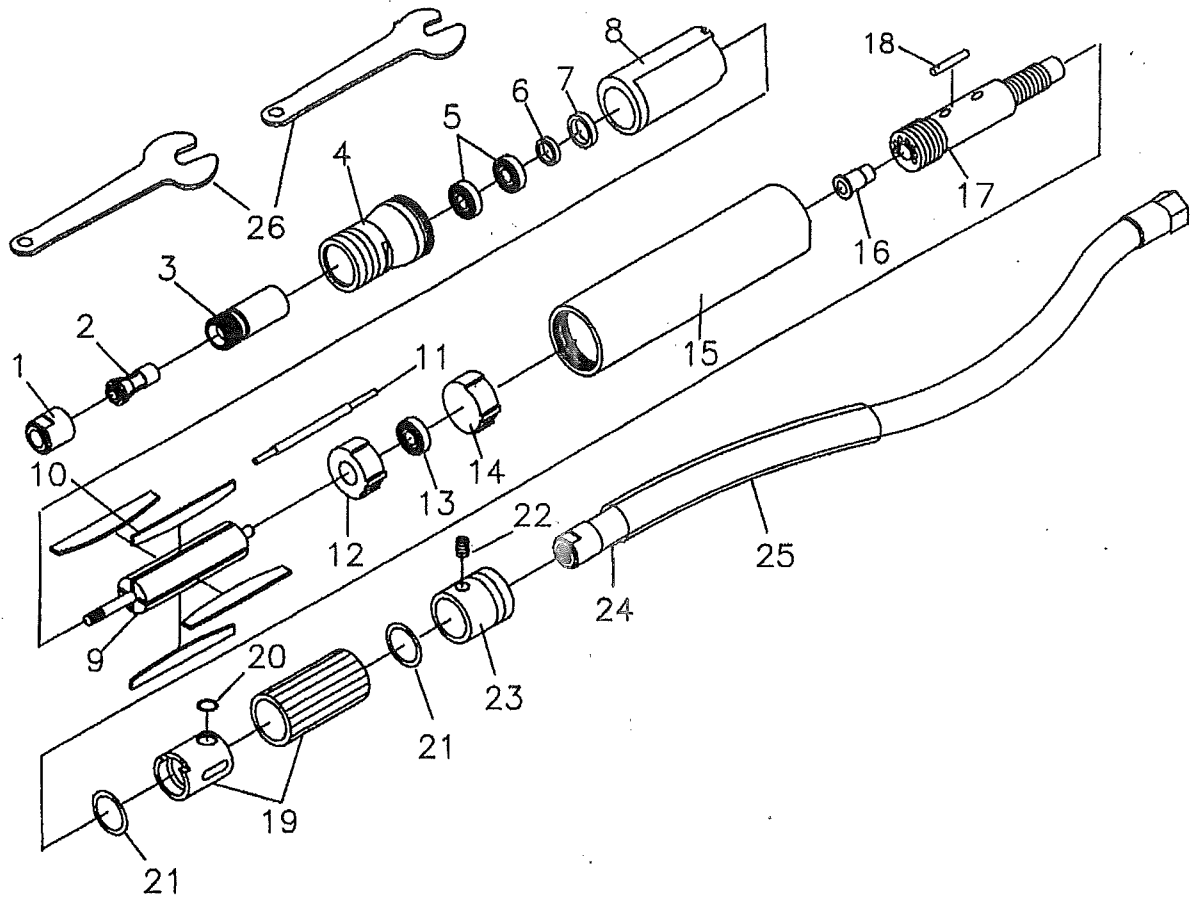

Ref. No.	Part No.	Description
1	AT1054-1	Clamping Nut
2	AT1054-2	Collet (1/8")
3	AT1054-3	Chuck Spindle
4	AT1054-4	Collet Foundation
5	AT1070-5	Ball Bearing (2)
6	AT1054-6	Spacer
7	AT1054-7	Lateral Disc
8	AT1070-8	Cylinder
9	AT1054B-1	Rotor
10	AT1054-10	Rotor Blade (4)
11	AT1054-11	Long Pin
12	AT1070-12	Bearing Plate
13	AT1070-13	Ball Bearing
14	AT1070-14	Intake Plate

Ref. No.	Part No.	Description
15	AT1070A-1	Body (Black)
16	AT1054-16	Intake Steel Tube
17	AT1070-17	Hose Plug
18	AT1054-18	Short Pin
19	AT1054-19	Sliding Knob w/Regulator
20	AT1054-20	O-Ring (3 x 2.2 mm)
21	AT803-29	O-Ring (10 x 2 mm) (2)
22	AT1054-21	Screw
23	AT1054-22	Rear End Holder
24	AT1070-23	Air Inlet with Black Hose
25	AT1054-23	Silencer
26	AT1054-24	Wrench (2)
Optional	AT1054-25	Collet (3 mm)
Not shown	SS1924	Warning Label

use an extension bar on the wrench and/or provide local heating to the thread area to soften and break the grip of the thread locking sealant. Separate ratchet housing (25) with needle bearing (23), bushing (24) from housing assembly (1). With a wide-blade screwdriver, pry bushing (24) to separate bushing (24) from ratchet housing (25). Use a suitable punch, tap needle bearing (23) out of ratchet housing (25). Separate planet gear carrier (22), planet gears (21), internal gear (20) Pull out motor assembly from housing with bushing (1). Grip the front end plate (18), to avoid the splines of rotor (16) from damage, use a rubber hammer, slightly tap the splined end of the rotor (16) through the front end plate (18) and ball bearing (19) assembly. Take off cylinder (15) and remove rotor blades (17). With a suitable punch, tap the rear end of rotor (16) slightly to separate rotor (16) from rear end plate (13). Then, press out ball bearing (19) from front end plate (18) and ball bearing (12) from rear end plate (13). Do not remove the steel balls (14) from front end plate (18) and rear end plate (13) unless replacements are required.

Reassemble

Clean all parts and examine for wear. Look in particular for wear and cracks on ratchet pawl (37), ratchet anvil (36) and ratchet yoke (28). Coat all parts with a pneumatic tool lubricating oil and grease ratchet mechanism parts with a molybdenum or lithium based general purpose grease. Before reassembling the motor, make sure that the faces of rear end plate (13) and front end plate (18) that abuts cylinder (15) are flat and free from burrs. If necessary, lap on a flat, very fine grade of abrasive paper. Reassemble in the reverse order. When refitting the complete motor assembly to the housing with bushing (1), make sure that the assembly is clamped tightly together and the rotor spins freely, ensure the steel ball (14) in the side of front end plate (18) locates in the slot in motor housing with bushing (1).

Notes

Operation Specification	
Air Consumption	3.5 cfm (25 scfm)
Maximum Torque	30 ft-lbs
Air Inlet Thread	1/4-18NPT
Overall Length	5.12" (130mm)
at 90 PSIG/6.2 Bar	

Trademark Acknowledgements
Snap-on® is a registered trademark of Snap-on Incorporated.

DECLARATION OF CONFORMITY

Manufacturer:

Snap-on Tools Company

2801 80th Street,
 Kenosha, WI 53141-1410, U.S.A.

Product: 1/8" (3 mm) Air Pencil Die Grinder

Model No.: AT1070A

Production date: 1607xxxx-xxxxxxx

The undersigned hereby declares, on behalf of the above referenced manufacturer and product(s), to which this declaration relates, is in conformity with the provisions of:

Machinery Directive: 2006/42/EC

Safety: ISO11148-9:2011

Vibration: ISO 28927-12:2012

Noise: ISO 15744:2002

Safety: ISO 12100:2010

The Technical Construction File is maintained at:

Snap-on Tools Company
 2801 80th Street
 Kenosha, WI 53141-1410, U.S.A.

The authorized representative located within the Community is:

Matthew Law
 Snap-on Tools Ltd
 Telford Way Industrial Estate
 Kettering, Northants
 NN16 8SN
 United Kingdom

 John Majerowski
 Director – Merchandise Products

Snap-on Tools Company

2801 80th Street,
 Kenosha, WI 53141-1410, U.S.A.

www.snapon.com

Jul. 2016