

PRODUCT ANNOUNCEMENT #20545
DATE: SEPTEMBER 15, 2003

INSERT INTO SPCAT3
SECTION N, PAGE 39

PARTS SUPPLEMENT TO:

FILE INDEX: 30.4
PH3050

PH3050 - Air Hammer

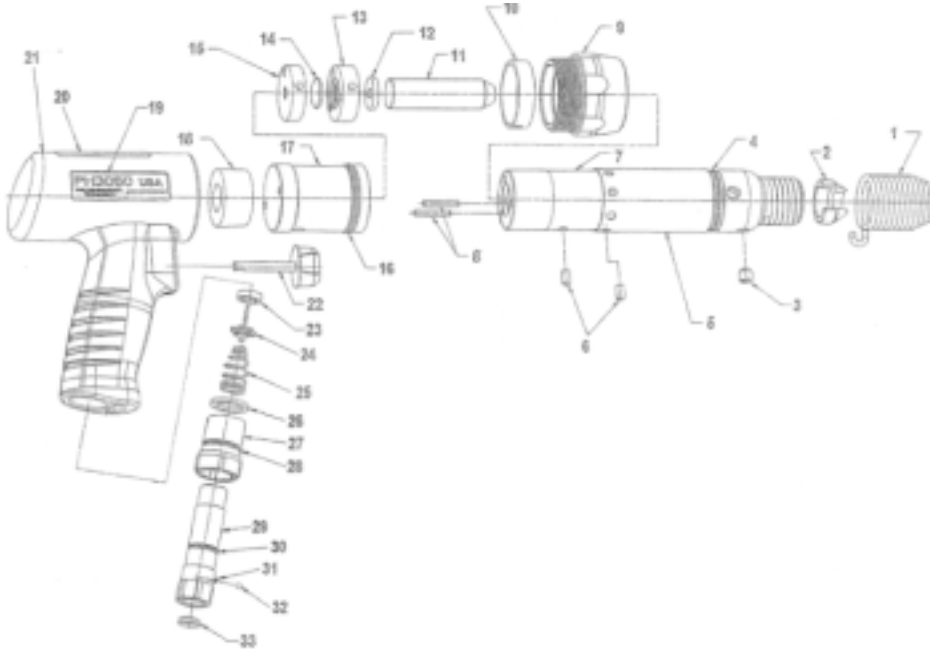

WARNING

- Wear safety goggles (operator and bystanders).
- Wear hearing protection (operator and bystanders).
- Avoid prolonged exposure to noise and vibration.
- Read instructions before using power tools.
- Avoid breathing power tool exhaust.
- Use only approved accessories.

Key	Stock Number	Description	Key	Stock Number	Description
1	PH50-11A	Spring, Beehive	18	PH3050-8	Rear Cushion
2	PH50-13	Bushing, Slotted	19	PH3050-10	Unit Nameplate
3	ME3F25A	Set Screw	20	SS2162	Warning Label
4	ME7B17	O-Ring	21	PH3050-1R	Housing Assembly (includes keys 19 & 20)
5	PH2050-4	Exhaust Deflector Sleeve	22	PH3050-14	Trigger & Stem Assembly
6	PH50C-8	Pin (2)	23	IM3100-22	Valve Seat
7	PH3050-3	Barrel	24	IM3100-20	Trigger Valve
8	ME2A151	Pin, Dowel (2)	25	ME1A269	Compression Spring
9	PH3050-12	Clamp Nut	26	ME5A172	Washer
10	PH3050-9	Front Shock Isolator	27	PH3050-17-2	Regulator Dial
11	PH3050-5	Piston	28	ME7B31	O-ring
12	PH3050-19	Impact Washer	29	PH3050-17-1	Regulator Inlet Bushing
13	PH3050-20	Front Valve Half	30	ME7B68	O-ring
14	PH3050-4	Valve Disc	31	ME1A133	Spring
15	PH3050-21	Rear Valve Half	32	ESD852	1/8" Ball
16	ME7B23J	O-Ring	33	PGS1-11	Air Filter
17	PH3050-6	End Cap			

PRINTED IN U.S.A.

©2003 Snap-on Tools Company Kenosha, WI
 Copying permitted for Snap-on customers only.
 SALES COMMUNICATIONS DEPARTMENT

Snap-on® is a registered trademark of Snap-on Technologies, Inc.